

See discussions, stats, and author profiles for this publication at: <https://www.researchgate.net/publication/317223048>

Power generation using gear setup with dynamo

Article · April 2017

CITATIONS

5

READS

21,212

3 authors, including:



Rubini Balakrishnan

Vels University

20 PUBLICATIONS 30 CITATIONS

SEE PROFILE



D. Ravikumar

DMI College of Engineering (Autonomous)

49 PUBLICATIONS 146 CITATIONS

SEE PROFILE



POWER GENERATION USING GEAR SETUP WITH DYNAMO

B. Rubini¹, K. Sasikala¹ and Ravikumar D.²

¹Department of Electrical and Electronics Engineering, VELS University, Chennai, India

²Department of Electronics and Communication Engineering, VELS University, Chennai, India

E Mail: rubini77@gmail.com

ABSTRACT

In this paper the Two Wheeler vehicle speed is used to generate the electricity which can be stored in the battery for further use. The self-power generating vehicle is the new innovative one which is going to replace during power cut period. The power generated from the synchronized dynamo is stored in the battery which is given to inverter circuit Utilized in AC low power Applications. Power Utilization from battery usage only applicable for the failure of power supply in homes used from grid line power. Hence this system will enhance the features and more useful for rural areas.

Keywords: IC engine, planetary gearbox, synchronized dynamo, lead acid battery.

1. INTRODUCTION

AC output to get from 12V DC battery which is converted into AC by means of an inverter circuit. The battery is charged by a DC synchronized dynamo and which is coupled with the planetary gear. The planetary gear train is connected with a bike chain sprocket using free wheel welded with planetary gear box input. Output of the gear box is coupled with DC dynamo by means of a Belt Drive. Synchronized dynamo is connected with charging unit & 12V DC Battery. Battery supply is given to an inverter circuit which inverts the 12V DC to 12VAC then utilized for low load Applications.

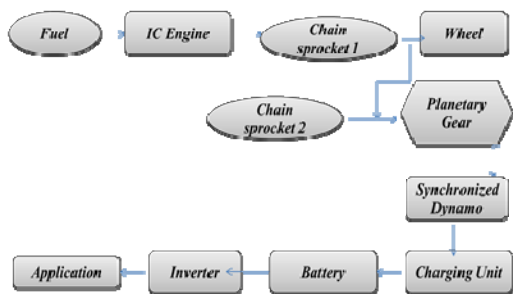

Figure-1. Block diagram of gear setup with dynamo.

2. COMPONENTS AND ITS FUNCTIONS

The generating of power we are taken from speed of vehicle with the help of external components. The following components are required to complete the operation of the machine.

- A. Engine B. Planetary Gear C. Dynamo
D. Rectifier and Inverter E. Battery

a) Engine

Motorcycle engines work periodic linear motion with piston which connected to a crankshaft by a piston-rod, which turns the linear motion into rotation. In the ignition stage the piston experiences a downward force on which increases its momentum. Exhaust, Intake and Compression these three stages the crankshaft acts as a flywheel which moves the piston for rotation. Hydrocarbons major component in petrol. carbon atoms and hydrogen atoms are

more in Hydrocarbons. They're useful as a fuel, because a carbon atom can combine with two oxygen atoms to make carbon dioxide, and two hydrogen's can combine with oxygen to make water (H₂O) [3]. Actually, as well as the carbon dioxide reaction, you get a single carbon reacting with single oxygen to make carbon monoxide (CO). This can then go on to react with more oxygen to make carbon dioxide. All these reactions release energy, which makes our piston move downwards. Engine consist of pistons, a cylinder block head, the valve train as one of a part. The pistons make progress in a to and fro direction in the cylinder block, driven by eruptions of a fuel-air mixture which has been triggered by a spark. To allow the air-fuel mixture to intrude into the combustion chamber, the valves are opened and closed. As the pistons make progress in a to and fro direction, crankshaft starts turn in a rotation the energy changes from the pistons into crankshaft. The rotational force of the crankshaft is transmitted via the transmission, to the front wheel of the motorcycle[1].

Motorcycle engines are categorized by three ways viz; (i) The number of cylinders working in engine. (ii) The combustion chambers capacity. (iii) The number piston moves in their power cycles.

Motor cycle used here has an activating combustion and a tub form double cradle type frame with a 97.2cc engine. The engine is having a basis on the Honda cub C100EX with a similar bore and a stroke of 50mm x 49.5mm [2].

Fuel tank capacity: 11 liters (2.4 imp gal; 2.9 US gal), Reserve: 1.4 liters (0.31 imp gal; 0.37 US gal)
Dry weight: 109kg.

b) Planetary gear

The epicyclic gearing system of a gear ratio was somewhat complicated; particularly there are several ways where a rotation of input can be converted into an output twirling [5]. Three basic components of the epicycle gears are:

Sun: The centre gear of gearing part.

Carrier: Planet gears all are same sizes and interlock with the sun gear which includes one or more peripheral gears.

Ring: An outermost ring with directed-facing teeth that netting with the planet gear or gears



The two planetary gears which interlock with one another are employed in the epicyclic gear trains. Out of these planets, one interlocks with the sun gear and another planet netting with the ring gear. This outcome in different ratios is being generated by the planetary gear. The elementary equation becomes:

$$(R-1) \omega_c = R\omega_r - \omega_s \text{ Where } R = N_r/N_s$$

this results in:

$$\omega_r = \omega_s (1/R) \text{ when the carrier is locked,}$$

$$\omega_r = \omega_c \left(\frac{1}{R} \right) \text{ when the sun is locked,}$$

$$\omega_s = -\omega_c (R-1) \text{ when the ring gear is locked.}$$

Gear Specifications:

Gear attached in engine = 100mm and 44 teeth

Gear attached in planetary gear box = 50 mm and 22 teeth

Space between the two gears = 350 mm



Figure-2. Planetary gear setup and synchronous dynamo.

c) Dynamo

Dynamo is an equipment which transforms the kinetic energy into electrical energy [4]. Bicycles require energy to power the head lights and other apparatus in the vehicle. Generally the dynamos are small permanent-magnet alternators. Synchronous dynamo explains the action of rotating an orbital body in the same amount of time on its axis. As it takes to complete a full orbit, continuous rotation toggles with planetary gear setup with this Synchronous dynamo. Dynamo starts continuous rotation with planetary gear. Experimental setup Fix with one stand with two wheel body. Chain sprocket running condition experimental setup fixed to produce rotational energy is converted into electrical energy (i.e) generate dc power [6]. The generated power is stored to the battery. It can be stored in the battery after rectification. The rectified voltage can be inverted and can be used in various forms of utilities. The battery power can be consumed for the users comfort.

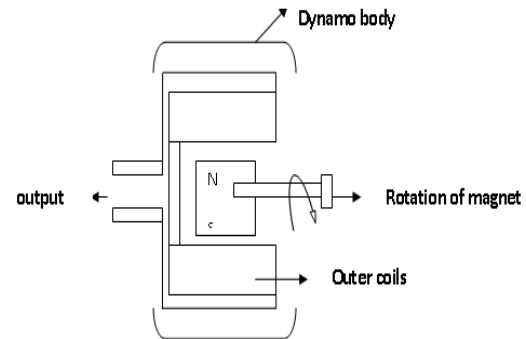

Figure-3. Dynamo.

Dynamo is generating an electrical signal. The dynamo internal parts inside consider for rotating coils of wire and magnetic fields to convert mechanical windings into a pulsing direct current. This dynamo and planetary gear system are connected through teeth belt drive. Dynamo consists of a stator; a stationary part gives a sustained magnetic field and a set of twirling windings called the armature which rotates within that magnetic field. The stationary magnetic field may be provided by one or more permanent magnets which are usually called field coils.

Lenz's law states that the commutator is needed to produce DC. The potential is induced in a magnetic field when a loop of wire rotates with each half turn reverses the polarity there by creating an sinusoidal current. Moreover, in the earlier days the process of performing a scientific procedure, sinusoidal current generally had no known use. In recent days the direct current provided by lead acetate batteries finds an application in the field of electroplating. The Dynamos were innovated as alternate equipment for Batteries. Contacts are mounted on the machine's shaft of the commutator, reverses the connection of the windings as the potential reverses to the external circuit, hence the alternating current, is produced instead of a pulsing DC.



Figure-4. Proposed hardware model-dynamo.



Dynamos were generators the first electrical energy use of conveying power in industry, including the electric motor, the sinusoidal current alternator, the rotary convertor [8].

Nowadays the elementary alternator influences large scale power generation, for efficiency, trustworthy and cheap of cost. A dynamo has the disadvantage of a mechanical commutator.

d) Rectifier and inverter

Silicon diodes are mostly used for rectifier's lower voltages and powers conversion Applications. The rectifier circuit was collect source from dynamo and rectify the source then given to the 12V (D.C) Battery charging unit. Lead acid Battery is reutilized by refilling solutions. Battery connected to inverter circuit, inverter to convert D.C to A.C. This paper designed for 220 V inverter circuit [7].

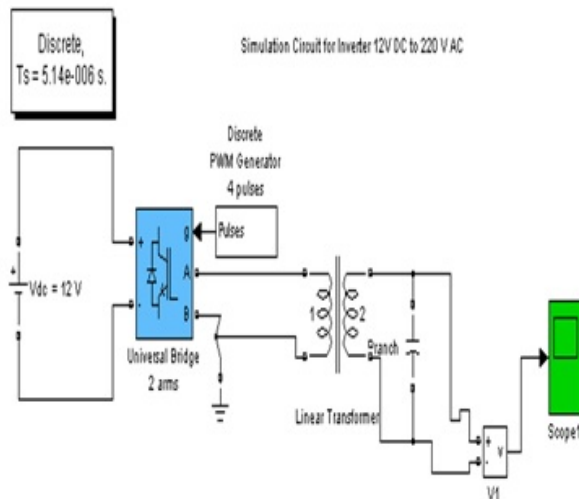

Figure-5. Simulation diagram for inverter circuit.

e) Battery

In this paper we are using secondary type lead acid battery [1]. It is reusable type. A battery is more electro chemical cells, inside battery which contains chemical solutions and makes it available as electric current. There are two types of batteries, primary (disposable) and secondary (rechargeable), both of which convert chemical energy to electrical energy. In this approach has also reduced the cost involved in the concern and also three main components involved to produce power generation.

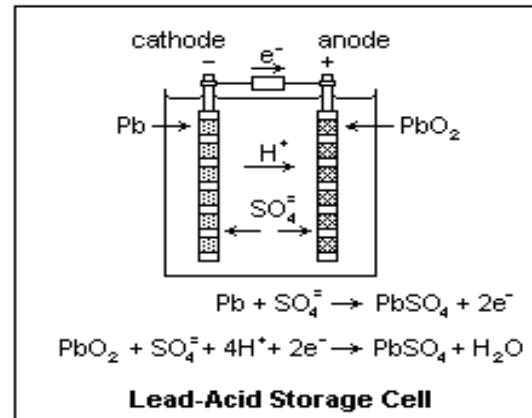

Figure-6. Lead acid battery.

EXPERIMENTAL SETUP SPECIFICATION

Planetary gearbox: 1:15 ratio speed
 Synchronized dynamo: 5 volt to 17 volt
 Lead acid battery: 12 volt 9 A/hr
 IC engine: 93 cc splendor+ engine
 Bike: Hero Honda Splendor
 The fuel consumption based on bike.
 Initial: 3 to 5volt.
 Starting: 5 to 7volt.
 RPM: 7000 to 7500 rpm, initial rpm=1000rpm.
 Battery: 12 Volt 9 Ah
 Standing fan = $75 \times 4 = 300w$
 Lamp = $40 \times 4 = 160w$
 Mobile charge = $3 \times 2 = 10w$
 Total = 470w
 Current = $470/230 = 2.04$ amps/per hour
 $2.04 \times 2 = 4.08$ amps
 Computer = 250w
 Home theater = 550w
 Current = $550/230 = 2.39$ amps (or) 3 amps
 Current = $250/230 = 1.08$ amps (or) 1.5amps

Battery rating

Calculation:

$$\frac{\text{Powerrating (watts)} \times \text{No. of appliances at home} \times \text{Avg no. hours used per day}}{1000} = \text{Total per day in KWH.}$$

$$\frac{\text{Powerrating (watts)} \times \text{Hours use} \times 30 \text{ days}}{1000} = \text{kwh}$$



Figure-7. Position of Hardware setup fixed with two wheeler.

3. SIMULATION RESULTS FOR INVERTER CIRCUIT

- This simulation results shows the inverter circuit. From Battery 12 V DC converted into inverter circuit 220 V AC supply. Specifications for inverter circuit board are containing following elements.
- IC SG3525
- MOFFETS IRF Z44 x2
- Resistors (22,10K,56K,12K,470,33×2,)
- Resistors(220×4 ½ watt)
- Capacitor (0.01uFx3, 1000uF/25V ,2.2uF/25V ,1K100,102K, 47uF/25Vx2)
- Transformer (we use as inverted).



Figure-8. Simulation wave form for inverter circuit.

CONCLUSIONS

This paper analysis the power cut period we are utilizing power through two wheeler connection with inverter circuits. The Components like chains sprocket, planetary gear setup, and synchronized dynamo. In this

paper experimental setup also identified the potentials of the technologies when incorporated with other devices to maximize potential energy efficiency of the vehicles. It is used to produce the current in vehicle speed unit. In this proposed model is very effective compare the existing development model.

REFERENCES

- [1] S. Vijaya Kumar, Amit Kumar Singh, Athul Sabu, Mohamed Farhan, "Generation Of Electricity By Using Exhaust From Bike" Vol. 4, Special Issue 6, May 2015.ISSN(Online) : 2319 – 8753.
- [2] R. Saidur A, M. Rezaei A, W. K. Muzammil A, M. H. Hassan A, S. Paria A, M. Hasanuzzaman B, N" Technologies To Recover Exhaust Heat From Internal Combustion Engines" 1364-0321/\$ -See front matter & 2012 Elsevier ltd. All rights reserved.
- [3] V. Ganesan," IC Engines", Fourth Edition, TATA Mcgraw Hill Publications, ISBN (10)-1-25-900619-0.
- [4] Kranthi Kumar, Guduru, Yakoob Kollpak, "Power Generation by Exhaust Gases on Diesel Engine". Vol.7 Issue.5 Page: 06-13 ISSN: 0975-5662, Dec, 2015.
- [5] Hyeoun-Dong Lee; Seung-Ki Sul; Han-Sang Cho; Jang-Moo Lee "Advanced gear-shifting and clutching strategy for a parallel-hybrid vehicle" IEEE Industry Applications Magazine Year: 2000, Volume: 6, Issue: 6 Pages: 26 - 32,
- [6] Krishna K. Uppalapati; Jonathan Z. Bird; Dan Jia; Joshua Garner; Aixi Zhou "Performance of a magnetic gear using ferrite magnets for low speed ocean power generation" 2012 IEEE Energy Conversion Congress and Exposition (ECCE),Year: 2012 Pages: 3348 - 3355,
- [7] B. El Badi, B. Bouzidi and A. Masmoudi, "DTC Scheme for a Four-Switch Inverter-Fed Induction Motor Emulating the Six-Switch Inverter Operation," IEEE Trans. Power Electron., vol. 28, no. 7, pp.3528-3538, Jul. 2013.
- [8] Z. Dehong, Z. Jin and L. Yang, "Predictive torque control scheme for three-phase four-switch inverter-fed induction motor drives with dc-link voltages offset suppression," IEEE Trans. Power Electron., vol. 30, no. 6, pp. 3309-3318, Jun. 2015.