



3rd International Conference on Evolutionary Computing and Mobile Sustainable Networks (ICECMSN 2023)

## UGVs for Agri Spray with AI assisted Paddy Crop disease Identification

K. Sujatha<sup>a\*</sup>, T. Kalpalatha Reddy<sup>b</sup>, N.P.G. Bhavani<sup>b\*</sup>, R.S. Ponmagal<sup>c</sup>, V. Srividhya<sup>d</sup>, N. Janaki<sup>e</sup>

<sup>a,b</sup>Professor, EEE/ECE Department, Dr. MGR Educational and Research Institute, Chennai-600095, India

<sup>b</sup>Asso Professor, ECE Department, Saveetha Institute of Medical Sciences, Chennai, India.

<sup>c</sup>Professor, CSE Department, SRM Institute of Science and Technology, Kattankolathur, India

<sup>d</sup>Asso Professor, EEE Department, Meenakshi College of Engineering, Chennai, India.

<sup>e</sup>Asst. Prof, Vels Institute of Science, Technology and Advanced Studies, Chennai, India.

[sujathak73586@gmail.com](mailto:sujathak73586@gmail.com), [sbreddy9999@gmail.com](mailto:sbreddy9999@gmail.com)

### Abstract

This research work involves data access and control of Unmanned Ground Vehicles (UGVs) which is designed for health monitoring of paddy crops as an exception from traditional monitoring system. The proposed scheme of autonomous navigation of drones is planned to be carried out as per the six milestones for disease detection and control in paddy crops. Drones serve as Unmanned Robotic Vehicles (URV) capable of performing desired tasks in unstructured, uncertain and potentially hostile environments and are remotely-operated without human intervention. URVs function completely as autonomous entities in diversified environments. Current UGVs adhere to different levels of automaticity. Typically the vehicle follows high level waypoints spaced for few hundred meters of distance to provide monitoring of agricultural fields and early detection of the various diseases that may occur in the paddy fields in a polyhouse. To increase the vehicle's abilities, tracking efficiency, obstacle avoidance, path planning or lead and follow up augmented control with Fuzzy Logic Controller (FLC) is incorporated. The distributed autonomous system for information gathering related to the paddy crops in polyhouse is enabled using different sensors, which is a data-intensive task. To increase the robustness of the system, fuzzy controllers are proposed to control the navigation of the proposed UGV in “All terrain conditions”. They are needed to offer problem specific heuristic control knowledge for the Inference Engine Design which occurs due to imprecision and uncertainty of the sensor readings. It also requires low computation time which favours the polyhouse situations. The navigation of UGV and the FLC action will in turn depend on “All terrain traversability” and “dead zone” monitoring. The proposed UGV model is capable of measuring the parameters associated with the paddy crops inside a polyhouse. The various diseases in paddy crops are False Smut (FS), Sheath Blight (SB), Rice Blast (RB), Leaf Scald (LS), Brown Spot (BS), Bacterial Leaf Blight (BLB) and Bakane (BE) which are detected using Convolutional Neural Network (CNN).

© 2024 The Authors. Published by Elsevier B.V.

This is an open access article under the CC BY-NC-ND license (<https://creativecommons.org/licenses/by-nc-nd/4.0>)

Peer-review under responsibility of the scientific committee of the 3rd International Conference on Evolutionary Computing and Mobile Sustainable Networks

*Keywords:* Median filtering; Improved Canny Algorithm; Convolutional Neural Networks (CNN); Paddy Crop Disease Identification; Unmanned Ground Vehicle

---

## 1. Introduction

Traditional methods in cultivation do not increase the productivity in agriculture industry [1]. The agriculture industry is of great importance and priority to the human race. In general, the physical structure of the rice grains contributes to the quality of the produce [2]. Impact of the natural conditions on agriculture was recently discussed by the economists of United States to combat the situation. This strategy is able to regulate the variables including soil quality, health of the paddy crops, spraying of fertilizers/insecticides under various climatic circumstances. UGVs consists of a data panel with data analytics to guide the farmers to adjust so that they change the inputs or growing methods to maximize the yield, with a preventative precaution against the natural calamities. Nevertheless, the AI technique offers long-term adaptation, such as polyhouse farming rather than giving up farming, by analyzing the effects of using artificial pesticides and insecticides [1].

The demand for rice is anticipated to increase at a faster rate as compared to the cultivation rate. Hence any kind of damages that may occur to the paddy crops will have a negative effect on the situation [2]. Identification of diseases in the paddy crops is a challenging task. In olden days, visual observation and analysis through naked eye was done by the farmers to diagnose the diseases in the paddy crops. Naked eye judgement incurs incessant monitoring of the paddy crops in the fields for exact determination of the diseases by the experienced farmers. Analysis by naked eyes, require consistent observations made by the farmers and tends to be very expensive, laborious and time-consuming for large areas of the paddy fields. Since the population is exponentially increasing the demand for the rice grains are also increasing rapidly. As a result, there arises a need in the society, for the implementation of advanced automated technology for early and accurate detection of diseases related to the paddy crops at an appropriate time. Image Processing (IP) and Artificially Intelligent (AI) techniques are the most powerful tools for forecasting the related parameters for the paddy crop diseases [2].

## 2. Literature Survey

A survey is carried out so as to throw light about the various diseases that may affect the paddy crops in the recent scenario. Hence, a consolidated insight about the current trends in agricultural industry is discussed by thorough analysis of the work carried out by the researchers from 2019 to 2023. Based on this survey a precise idea is shared on various plant disease detection techniques. On time detection of diseases in rice plants leads to loss in agricultural yields. The researchers like, Basavaraj S. Anami., et al., in 2020 [3] has rightly indicated that the conventional ways of disease detection in paddy crops depends on the eye judgement made by the farmers which is predominantly exposed at acute stages only. So, to avoid the destruction caused by the pests to the paddy crops, an automated system using Deep Convolutional Neural Networks (DCNN) is proposed. This system is capable of eliminating the mistakes that may occur due to visual judgements made by the farmers. Nearly, thirty thousand images with five varieties of paddy crops affected by twelve various diseases are used for developing the expert system with an efficiency of 92.89% [6]. In the year 2020, Victor Partel, et al., [2] has pointed out that the usage of man-made fertilizers by the farmers has drastically increased to earn more money. This method of artificial treatment will lead to soil pollution and is subjected to the persistence of pesticides by the paddy crops. Hence, an AI based vision machine system for healthy monitoring of rice plants is developed with an efficiency of 78% [3].

The backbone of Indian economy is agriculture. Since the world's population is increasing rapidly, the farmers are put a great challenge in increasing the quality and quantity of agricultural produce in a short period of time. The state of the art method proposed by Tanha Talaviya., et al., has created a path for incorporating recent

trends in agriculture in the year 2020. Artificial Intelligence (AI) with sensor technology and embedded systems are widely used to construct surveillance robots. Such sophisticated methods will tend to upgrade the productivity maintaining optimal agricultural conditions [4]. In 2020, Yiannis Ampatzidis et al., [4] designed a miniature Unmanned Aerial Vehicles (UAVs) for disease control. Manual identification of plant diseases is hilarious and tedious. The designed UAV is used to gather data in short time span with optimal cost. This UAV is equipped with facility to gather satellite images and their related geospatial information to locate the plants and plant related measurements like the growth parameters. Validation of the proposed model yielded a Mean Absolute Error (MAPE) is 2.3% [5,6,7].

In 2019, Tejal Chandiwade et al. [11], have proposed a scheme for plant disease detection using segmentation. This method is used to identify the plant diseases, detect them and offer a suitable pesticide for protection against a specific disease. The plant database is divided into two parts for identification of plant disease which is attained by scrutinizing the infected plants. Convolutional Neural Network (CNN) was used for this purpose. A prototype drone model is built with high-resolution cameras to capture the images of the plants. The AI algorithms then process these photographs in order to assess the plant's health. Support vector machines (SVM) and Artificial Neural Networks (ANN) are also employed for this. Nearly, 78% of accuracy is achieved.

The control of plant disease is crucial in this dynamic world, according to Yan Guo et al. in 2020 [11]. A mathematical model was created for accurate and effective training for identifying the plant diseases. In a complicated environment, RPN is utilised to locate and identify the leaves. Machine learning algorithms were used to detect various types of diseases like black rot, bacterial plaque, and rust disease. The proposed approach yielded an accuracy of 83.57% in detecting the plant diseases correctly. Aliyu M. Abdu et al. [12] presented an image processing approach for plant disease identification in 2020 for monitoring the frequency and severity of crop variability. SVM and DL algorithms are compared here to detect the plant disease. Until then, many researchers have used only shallow machine learning algorithms combined with image recognition techniques. Many hurdles were faced by the researchers in evolving and getting adapted to a novel technology in agriculture industry. For developing nations, agriculture is the backbone of the nation's economy so as to implement sophisticated methods in irrigation. That is really challenging in the vast majority of nations. It presents a problem because it needs varied statistical data about the region being developed if the developed countries are thought of for implementing new agricultural methods to combat climate change.

### 3. Convolutional Neural Network (CNN) – A Background Study

CNN is the most popular architecture where features from input images are learnt at different convolutional levels which is similar to the function of the human brain. The different layers of CNN and their functions include an Input Layer where the data is processed. The input size for the model used is  $256 \times 256 \times 3$ . In Convolutional Layer the basic Convolution operation is carried by finding the dot product of the kernel or filter and the patch of an image of same size. It involves the application of filters to the input image for the purpose of feature extraction which forms the featured map or the convoluted map. Filters can be of different sizes like  $3 \times 3$ ,  $5 \times 5$ ,  $7 \times 7$  or  $11 \times 11$ . In this study, a smaller kernel size of  $3 \times 3$  is chosen. In 2012, it was observed that architectures that used larger kernel sizes like  $11 \times 11$ ,  $5 \times 5$  required 2 additional GPUs and consumed 2-3 weeks in training [4]. So because of the expensiveness and the extremely longer training time taken, it is always preferred not to use such larger kernel sizes. CNN networks introduced in 2015 replaced large convolutional layers by  $3 \times 3$  kernel sizes to reduce computational costs and weight sharing that ultimately leads to lesser weights for back-propagation. The Max Pooling Layer shoots up the parameters of the image after performing convolution. This layer will down sample the detection of features in feature maps. Then, batch normalization is done by training deep neural networks, the learning process is stabilized and the number of epochs is reduced using batch normalization. The ReLu Activation where all the neurons are not activated at the same time with ReLu activation and hence this activation is computationally efficient compared to 'tan h' and Sigmoid function. The Fully Connected Layers (FC Layers) utilises the results of convolutional or pooling layer to classify the images of the paddy fields. The Dropout layer performs a technique with the goal to exclude overfitting and minimize the complexity of a

structure. Finally, the Classification layer or Softmax Layer with Softmax activation function is used in the classification layer which performs the classification. Sigmoid activation function is used for binary classifications [8,9]. The implementation of CNN involves the usage of filters of various like  $3 \times 3$ ,  $5 \times 5$ ,  $7 \times 7$  or  $11 \times 11$  which is equivalent to reducing the feature size and in this case a  $3 \times 3$  kernel size is used for feature reduction. The choice of the random functions are made based on values of True Positive (TP), True Negative (TN) and False Positive (FP) values achieved after training is over using the widely adopted CNN frameworks, namely AlexNet, DenseNet and ResNet. Rectified linear unit (ReLU) is used as the random activation function.

### 3.1 Morphology of growth phases and diseases of Paddy crops

The diseases in paddy crops may occur due to various organisms like virus, bacteria and fungi. The three major reasons for the occurrence of the diseases are the pathogens, pests and lack of soil nutrients creating an abnormal environment for the growth of the paddy crops [5-6]. The diseases include False Smut (FS), Sheath Blight (SB), Rice Blast (RB), Leaf Scald (LS), Brown Spot (BS), Bacterial Leaf Blight (BLB) and Bakane (BE). All the seven diseases are clearly marked by distinct changes in the color and appearance of the paddy crops. This will enable the extraction of distinct features from the images of the paddy crops for onset of disease identification. There are three growth phases for the paddy crops across which these diseases may be spread out over a period of three to six months. They are the vegetative phase, reproductive phase, and ripening phase.

### 3.2. Fuzzy Logic Controller (FLC)

- Partition the universe of discourse for each variable into a number of fuzzy subsets, assigning each a linguistic label.
  - Assign a membership function for each fuzzy subset.
  - Form the rule base.
  - Choose appropriate scaling factors for the input and output variables in order to normalize the variables to the  $[0, 1]$  interval.
  - Fuzzification of the controller inputs and use of fuzzy approximate reasoning to infer the output contributed from each rule.
  - Aggregate the fuzzy outputs recommended by each rule and apply defuzzification to form a crisp output.
- Schematic for Agri-Spray UGV navigation using FLC is shown in below fig 1.

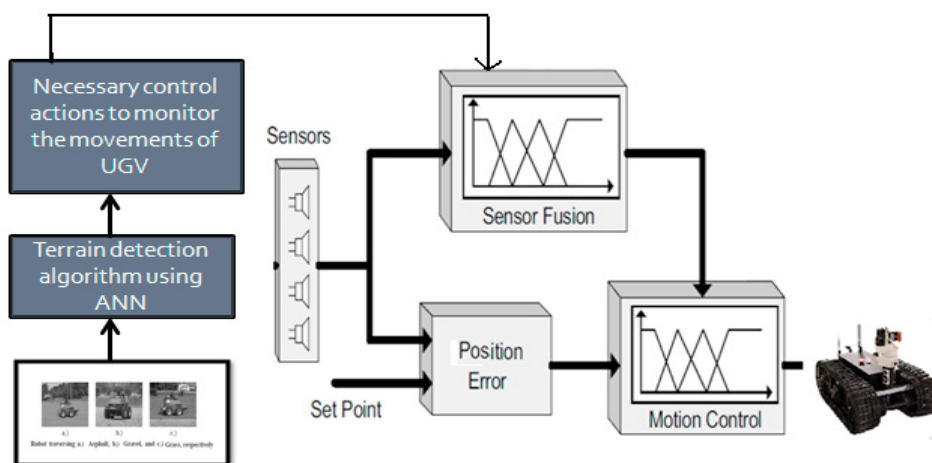

Fig. 1. Schematic for Agri-Spray UGV navigation using FLC

#### 4. Problem Statement and Objectives

Agriculture industry is dependent on climatic variations, healthy crops can be cultivated. Studies on agriculture have raised significant awareness relating to many real time problems. According to plant and soil research, agriculture can produce the most under the current circumstances. Truly, estimating agricultural yields for crops produced in greenhouses under different weather conditions is difficult. The main goal is to provide farmers with a way to apply artificial intelligence (AI) approaches to adjust and maintain agricultural yields in polyhouse farming for climatic and environmental changes. Variations in weather have a significant impact on agricultural productivity. In order to automate the temperature, light, CO<sub>2</sub> levels, soil moisture level, nutrients, False Smut (FS), Sheath Blight (SB), Rice Blast (RB), Leaf Scald (LS), Brown Spot (BS), Bacterial Leaf Blight (BLB) and Bakane (BE) and insect control despite the weather conditions, forecasting the parameters inside a greenhouse is helpful. AI algorithms then direct farmers through Short Message Service (SMS) to adjust the soil parameters according to weather conditions. The objectives include climate factor variation inside a poly-house and its impact on plant diseases, plant health monitoring and disease detection based on observable patterns using image processing algorithms and AI algorithms, the stressors inside a poly-house can be identified and controlled quickly.

#### 5. Strategy for parameter monitoring in polyhouse

UGVs equipped with night vision cameras are used for surveillance. The HoG features are identified after noise removal. Data on soil moisture are combined with these attributes, in order to forecast the soil moisture content, temperature, light intensity, CO<sub>2</sub> levels, various diseases in paddy crops and soil nutrients as illustrated in Figures 2 depicts the basic structure for the CNN. Totally, 235 samples are used. Highly disease Affected Paddy crops (HAP), Moderately disease Affected Paddy crops (MAP) and Less disease Affected Paddy crops (LAP) lands denote the effect of greenhouse gases, which also cause an increase in temperature and a decrease in rainfall. The proposed scheme is developed by training with 174 samples and testing with 61 samples. Noise may or may not distort these photographs, removed by the median filter. From the filtered photos, Table 1 tabulates the input-output for the samples. The farmers can choose a corrective action to conserve them for boosting the productivity by battling the climate change by adjusting the parameters. MATLAB software is used to conduct this experiment. The hardware model of the proposed setup can be developed using an Arudino board connected with camera, soil moisture sensor (inputs) and mobile for sending SMS. Red, Green, and Blue (R, G, and B) planes are typically used in the processing of colour images in order to extract meaningful information depending on pixel intensity. This subject is very important since the photos of the plants within a polyhouse that are taken are coloured photos. The quality and quantity of chlorophyll in a polyhouse determines the colour of the leaves inside. This colour range is divided into HAP, MAP, and LAP lands. A novel approach is therefore suggested to gauge and predict the paddy crop diseases, soil moisture content, temperature, light intensity, CO<sub>2</sub> levels, nutrients, and insect management inside a greenhouse. The aid of locally developed technology equipped with SMS capabilities, facilitates the messaging which helps the agricultural society.

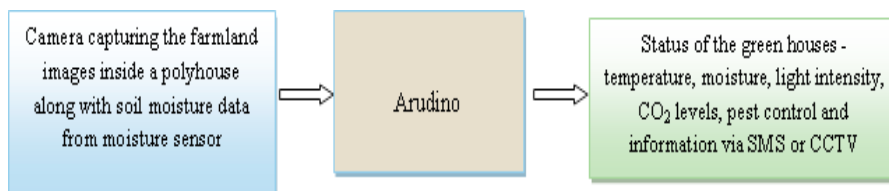

Fig.2(a). Schematic for Parameter monitoring in Polyhouse

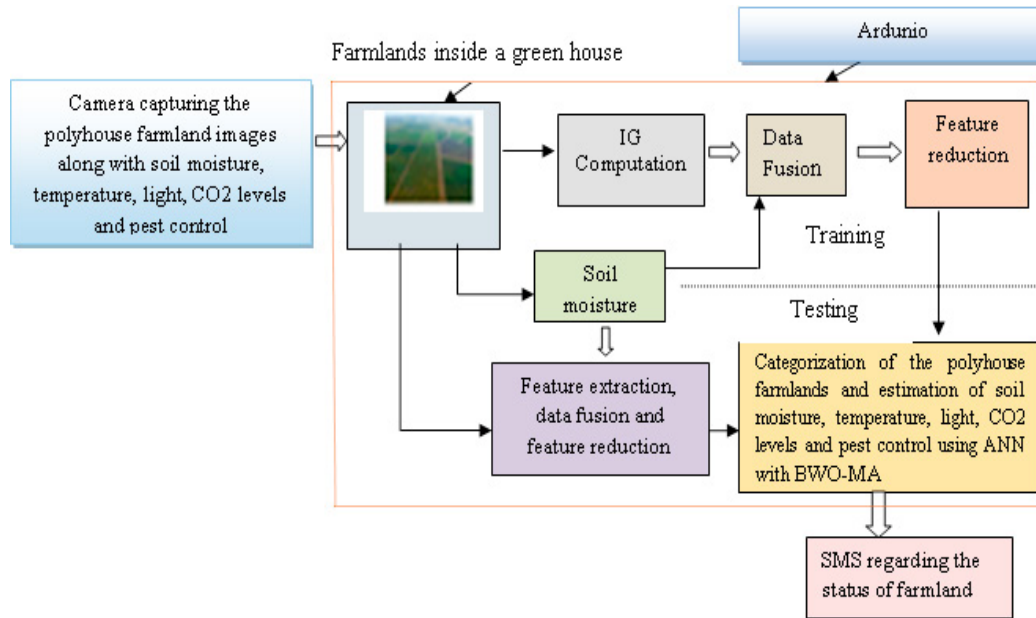

Fig.2(b). Block diagram for using Image Processing to measure and forecast the parameters inside a greenhouse using UGV

The data for the farmlands in a greenhouse was obtained and the images were captured along with the corresponding paddy crop diseases soil moisture, temperature, light, CO<sub>2</sub> levels and pest control measure tabulated in Table 1. The images of the plants inside a polyhouse (HAP, MAP and LAP) are captured by the night vision cameras in the agricultural lands. After pre-processing of photos, features are retrieved, combined with soil moisture data, and reduced using CNN model. Following that, these real-time variables are normalised using the  $X_i/X_{max}$  algorithm. A suitable architecture for CNN model with a set of weights made up of random integers generated using ‘randomise’ function is selected. Subsequently, training/testing are conducted using, 50 samples spread over in the category of HAP, MAP, and LAP with the forecasted and controlled parameters inside a greenhouse.

### 5.1. Object Recognition in UGV

To recognize and identify an object, the video of the object is captured using the camera. The stationary or non-stationary objects which are captured are divided into frames. The features extracted from various images are stored in the database for reference. The same set of features is once again extracted from the captured images. The distance measure is computed to identify the similarity between them. This event of recognition is then transmitted to the control room to offer necessary action.

### 5.2. Terrain detection using Artificial Neural Networks (CNN)

The various stages involved in terrain detection involve acquisition of the video, splitting the video into frames. The frames are then pre-processed to remove noise. The features are extracted and classified using CNN.

## 6. Results and Discussion

Intensity for green coloured pixels are computed for the plants housed in a poly-house in the HAP category are estimated to have a histogram count of 277. The histogram count is 42 for green pixels and 0 as intensity values for the plants cultivated in polyhouses in the MAP and LAP categories, respectively. Consider this value to be the

letter "X." According to this, the photos corresponding to MAP and LAP each have a lower concentration of chlorophyll or none at all. By calculating the sensitivity and validating its output by identifying the True Positive (TP), False Positive (FP), True Negative (TN), and False Negative (FN), it is possible to determine the success rate of this fusion logic (FN). Positive is typically recognised, whereas negative is generally disregarded. Thus, a true positive means that the presence of chlorophyll was correctly identified; a false positive means that the presence of chlorophyll was incorrectly identified; a true negative means that the presence of chlorophyll was correctly rejected; and a false negative means that the presence of chlorophyll was incorrectly rejected. Table 3 provides values for sensitivity, also known as True Positive Rate (TPR), which is defined as  $TP/(TP+FN)$ . Figure 3 (a) to (f) depicts the predicting the greenhouse gases, paddy crop diseases and air temperature respectively, along with the training parameters. The forecasting efficiency is lastly displayed in Table 4, which is defined as the proportion of parameters forecasted properly from photographs to the total number of images in that category. The developed Agri Spray UGV is used for the agriculture purpose to spray pesticides and in several places by lifting an maximum payload up to 5 kg. By using UGVs, the human intervention for spraying the pesticides can be reduced, so that farmers are not exposed to the chemicals used in pesticides.

Table.1. Plant Growth parameters for cultivation in Green house with related data and Images



S. No	Images of Agricultural lands inside a polyhouse	Type of productivity	CO <sub>2</sub> levels (cm <sup>3</sup> /hr)	Atmospheric temperature °C	Moisture content	Light intensity	Pest control	Proposed corrective action by farmers
1.		HAP	400	27	98%	0.33	0.898	No corrective action required
2.		MAP	700	32	60%	0.253	0.676	more water for manure and irrigation
3.		LAP	1000	43	30%	0.121	0.233	Growing seasonal crops may be favoured.

Image processing techniques are proven to be one of the accurate and economic practices for measuring the parameters related to various plant diseases. Therefore, a rigorous survey and comparative analysis of different techniques is carried out here, which are applicable for diagnosis of plant diseases. The strategy for implementing image-based analysis incorporates feature extraction technique which concentrates on segregating the paddy separately even in the images with partial information. The method involves the conversion of RGB image to an equivalent binary image using automatic threshold value. The success rate of the proposed AI model is dependent on the choice of the feature selection. Figure 3(a) to (e) denotes the prediction results by the AlexNet CNN model for forecast of the parameters like CO<sub>2</sub> level, light intensity, pest control rate, moisture level and temperature required for the growth of the paddy crops inside a polyhouse. All the mentioned parameters are measured and based on the intensity of the disease the respective pesticide is being sprayed in predetermined level by the Agri-spray UGV which is incorporated with Fuzzy Logic Controller (FLC) for speed automation and control inside a polyhouse environment avoiding the human interference for spraying the pesticides. The action of the fuzzy controller is demonstrated in Figure 4 for all the three categories of paddy crop disease detection. Table 2 indicates the specifications for FLC. Among the different types of membership functions available in MATLAB tool box, triangular membership function is found to provide consistency in mapping the linguistic variables with the crisp

values. The choice of the defuzzification method used is the area of centroid method. This method is found to offer smooth control action in the dead zone also.



(a). Estimation of CO<sub>2</sub>Level

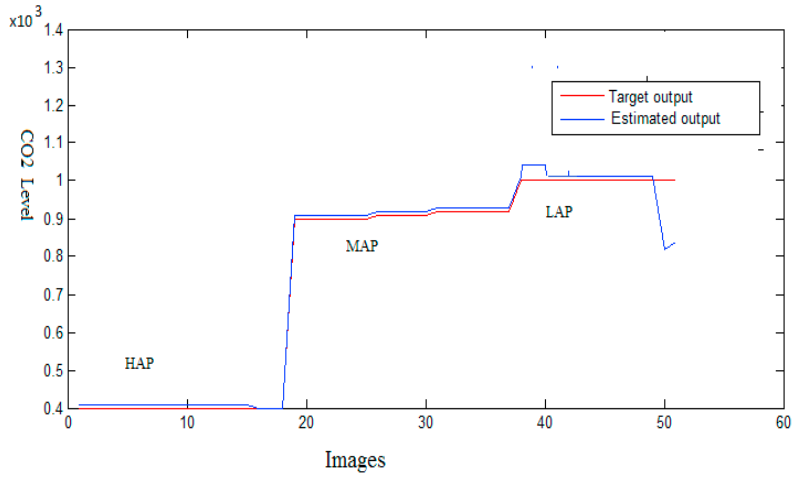
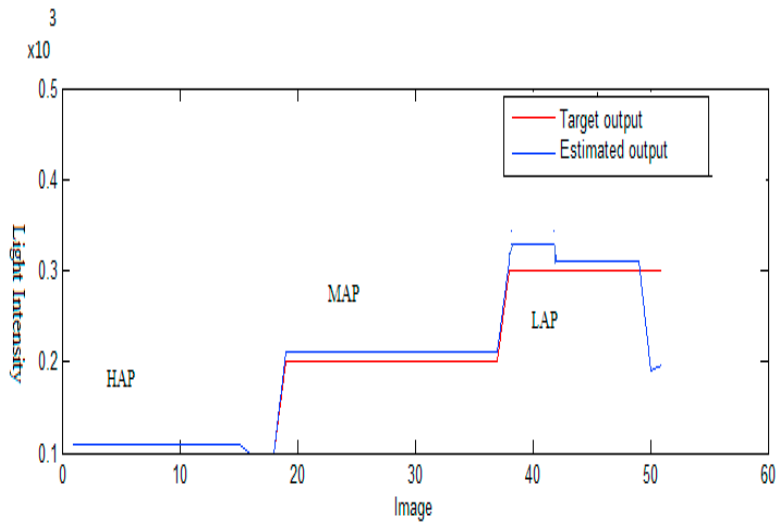

(b). Estimation of Light Intensity



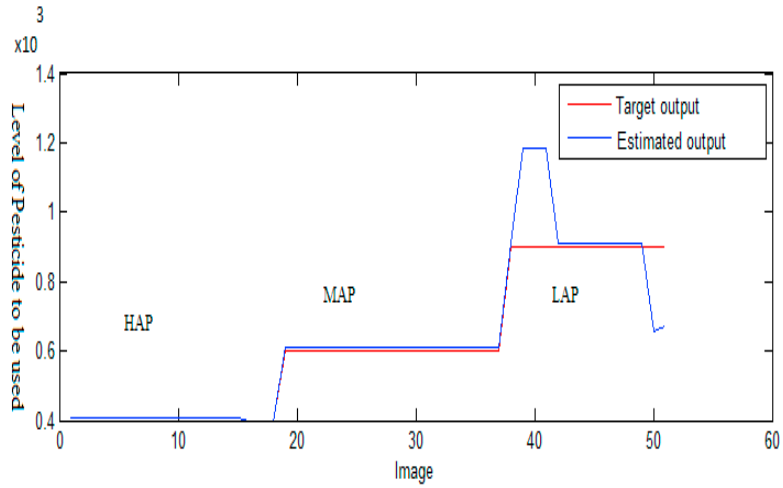

(c). Prediction of Pest control

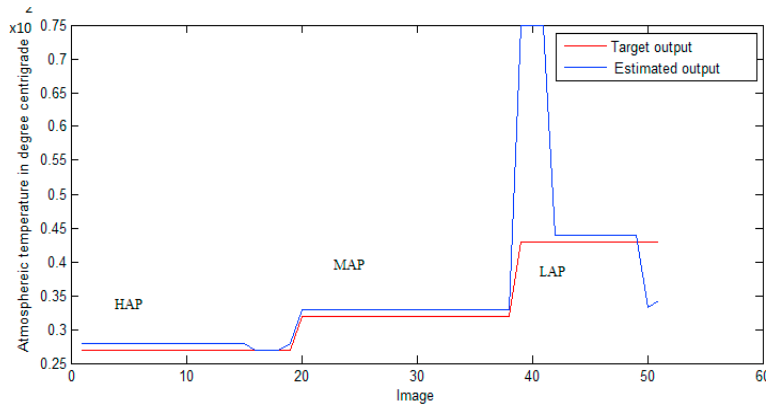

(d). Forecasting the Temperature

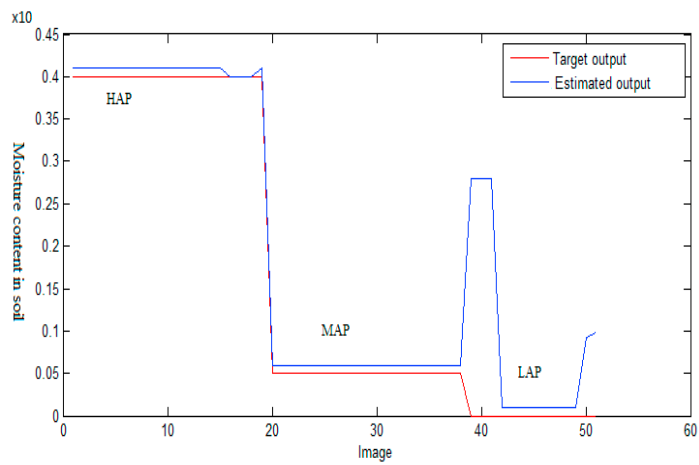

(e). Estimation of Moisture content in soil

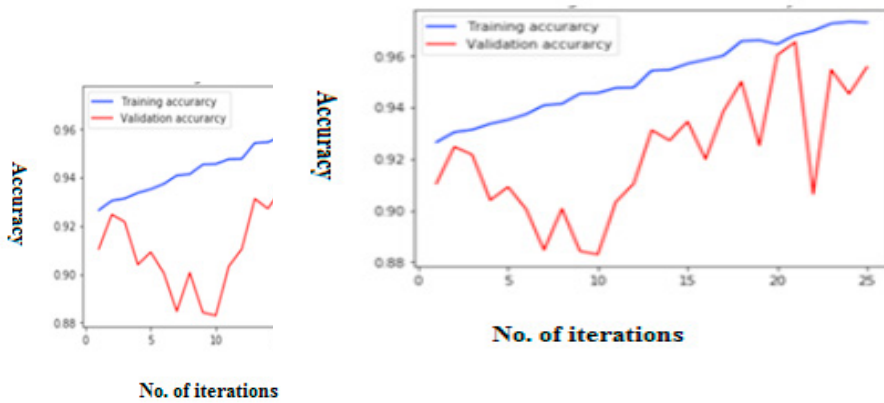

(f). Model Accuracy

Fig. 3. Prediction by CNN -AlexNet

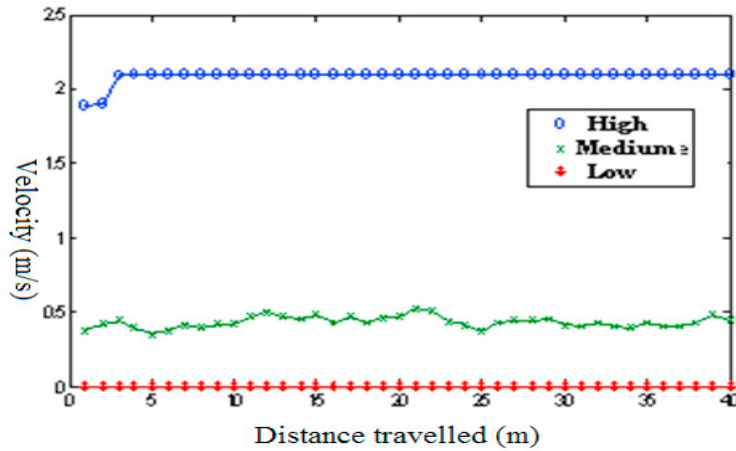

Fig. 4. FLC output for speed control of the Agri-Spray UGV

Table 2. Specifications for FLC

S.No	Specifications	Type/Quantity
1.	Linguistic variables	High, Medium and Low – 3
2.	Membership function	Triangular membership function
3.	Decision Making Logic	Min-Max criterion
4.	Defuzzification Method	Area of centroid
5.	Fuzzy rules	30 rules
6.	Input variables – error and change in error	0.001 to 0.1
7.	Output variable	Controlled speed level

In this work, three models of CNN pretrained with AlexNet, DenseNet and ResNet with a 5-layered network architecture proposed for the dataset representing 7 types of diseases that may occur in paddy crops with nearly 50 images corresponding to each disease type in paddy crops. The proposed AlexNet model has highest accuracy of 99.16% (Figure 5) compared to the accuracy of other two models. The proposed model has better testing accuracy for all classes and ranges from 93% to 99.16%.

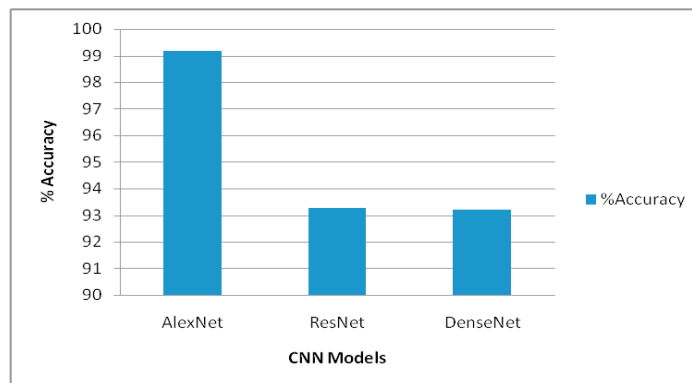

Fig. 5. Accuracy Analysis for CNN methods

Careful analysis indicates that the accuracy results achieved is 99.16% for ResNet, indicating its strong performance in accurately classifying the various types of diseased and healthy paddy crops. In CNN-based paddy crop disease detection, accuracy of the performance measure plays a crucial role in evaluating the effectiveness of the models. This metric is derived from the concept of True Positive (TP), False Negative (FN), True Negative (TN), and False Positive (FP). The definitions of these metrics are as follows:

**True Positive (TP):** It represents the number of correctly classified positive instances, i.e., the number of diseased paddy crops correctly identified by the CNN model.

**False Negative (FN):** It refers to the number of positive instances that were incorrectly classified as negative, i.e., the number of diseased paddy crops that were wrongly identified as healthy or undetected by the CNN model.

**True Negative (TN):** It represents the number of correctly classified negative instances, i.e., the number of healthy paddy crops correctly identified by the CNN model.

**False Positive (FP):** It refers to the number of negative instances that were incorrectly classified as positive, i.e., the number of healthy paddy crops that were wrongly identified as diseased by the CNN model.

The accuracy for disease detection is broadly classified under three categories namely, Highly Disease Affected Paddy Crops (HAP), Moderately Disease Affected Paddy Crops (MAP) and Less Disease Affected Paddy Crops (LAP) and is indicated in Table 3.

Table. 3. Performance Evaluation for ResNet CNN model

S.No	Agricultural Land category	True positive (TP)	False positive (FP)	True negative (TN)	% Accuracy
1.	HAP	17	0	0	99.19
2.	MAP	19	0	0	99.21
3.	LAP	11	0	0	99.32

## 7. Conclusion

This kind of forecasting the parameters inside a greenhouse will not only be helpful to the entire world wherever the agricultural industries are operated. This will allow the farmers to be informed in advance of changes in the climate and diseases at an early stage. Hence this scheme will be utilized by all farmers, researchers, agricultural students and people working in the area of machine learning algorithms. Many plant diseases can be detected using image processing algorithms using a common set of features which have a unique value and show subsequent variation for various types of plant diseases. The proposed plan can meet the needs of the expanding world population and raise their standard of living. Monitoring and controlling poly-house characteristics using GSM is dependent on accurately capturing the conditions because there is an increasing need for entirely healthy, diversified foods. On the basis of techniques for identifying and evaluating the individual trees and plants, a precise and effective crop management technique can be created. A cloud-based AI algorithm will be used by this system to automatically process, examine, and visualise the photographs of the plants that were recorded.

## References

- [1]. Latief Ahmad, "Automation, Sensor & IoT application in Protected Cultivation Technology", NAHEP Sponsored 5 days training on "Green House Start-up: Grow Smart to Go Green"Affiliation: Sher-e-Kashmir University of Agricultural Sciences and Technology of Kashmir, 2020.
- [2]. Victor Partel, Sri Charan Kakarla, Yiannis Ampatzidis, "Development and evaluation of a low-cost and smart technology for precision weed management utilizing artificial, intelligence", Computers and Electronics in Agriculture, 2019.
- [3]. Basavaraj S. Anami, Naveen N. Malvade,Surendra Palaiah, "Deep learning approach for recognition and classification of yield affecting paddy crop stresses using field images", Artificial Intelligence in Agriculture, 2020.
- [4]. Yiannis Ampatzidis, Victor Partel, Lucas Costa, Agrovie: Cloud-based application to process, analyze and visualize UAV collected data for precision agriculture applications utilizing artificial intelligence, Computers and Electronics in Agriculture, 2020.
- [5]. Tanha Talaviya, Dhara Shah,Nivedita Patel, Hiteshri Yagnik, Manan Shah, "Implementation of artificial intelligence in agriculture for optimisation of irrigation and application of pesticides and herbicides", Artificial Intelligence in Agriculture, 2020.
- [6]. Bhupinder Verma, " Image Processing Techniques for Grading Classification of Rice", International Conference on Computer and Communication Technology (IC CCT), pp. 220-223, 2012.
- [7]. N. A. Kuchekar, V. V. Yerigeri, "Rice Grain Quality Grading Using Digital Image Processing Techniques", IOSR Journal of Electronics and Communication Engineering, Volume 13, Issue 3, pp: 84-88, 2018.
- [8]. Harpreet Kaur, Baljit Singh, " Classification Grading Rice using Multi-Class SVM ", International Journal of Scientific and Research Publications, Vol. 3, Issue 4, April 2013.
- [9]. Ruchi Bansal, Jagdeep Singh, Ranjodh Kaur, "Machine learning and its applications: A Review",Journal of Applied Science and Computations, Vol VI, Issue VI, pp: 1392-1398, 2019.
- [10].Qing Yao, Jianhua Chen, Zexin Guan, "Inspection of rice appearance quality using machine vision", Global Congress on Intelligent Systems, 2009.
- [11].Tejas G. Patil, Sanjay P. Shekhawat, Artificial Neural Based Quality Assessment of Guava Fruit, Evergreen - Joint Journal of Novel Carbon Resource Sciences and Green Asia Strategy, pp: 389-395, 2022.
- [12].A. Dey., A Brief Review of Machine Learning and its Application, International Journal of Computer Science and Information Technologies, Vol.7,pp:1174-1179, 2017.
- [13]. S. Diksha, K. Neeraj., A Review on Machine Learning Algorithms, Tasks and Applications, International Journal of Advanced Research in Computer Engineering and Technology,Vol. 6,pp:1548- 1551, 2017.
- [14].H. M. K. K. M. B. Herath, G. M. K. B. Karunasena and R. D. D. Prematilake ., Computer Vision for Agro-Foods: Investigating a Method for Grading Rice Grain Quality in Sri Lanka, Transactions on Computer Systems and Networks, Vol:502., pp 21–34, 2022.