

Available online at [www.sciencedirect.com](http://www.sciencedirect.com)

**jmr&t**  
Journal of Materials Research and Technology  
journal homepage: [www.elsevier.com/locate/jmrt](http://www.elsevier.com/locate/jmrt)



## Review Article

# Optimization of crown and pinion using metal matrix composite



R.Charles Godwin\*, C. Dhanasekaran

Department of Mechanical Engineering, Vels Institute of Science, Technology & Advanced Studies Chennai 600117, Tamilnadu, India

### ARTICLE INFO

#### Article history:

Received 19 August 2021

Accepted 13 October 2021

Available online 1 November 2021

#### Keywords:

Crown pinion

Metal matrix composite (MMC)

3D modelling

ANSYS

Static load

Tangential load

### ABSTRACT

In automobile industries, the differential plays an important role in transfer motion from engine to rear wheels. Vehicles are having single axle differential and double axle differentials, depending on the load-carrying capacity. The crown and pinion gears have been involved as a foremost theme of research interest, in the case of resolving major issues such as wear and lifespan. This study aims to generate a computational model of the crown and pinion gear using Finite element analysis. The individualities of a crown and pinion gear at dynamic conditions, load carrying capacity, and stresses are tried in this research. Low carbon steel, high carbon steel and high carbon steel with Silicon Carbide (at various proportions) are used as materials to verifying the suitability of crown pinion. Finally, the generated analytical results of individual material are compared and concluded that high carbon steel performs good in structurally in dynamic condition.

© 2021 Published by Elsevier B.V. This is an open access article under the CC BY-NC-ND license (<http://creativecommons.org/licenses/by-nc-nd/4.0/>).

## 1. Introduction

Gear is a mechanical device used in transmission systems that allows rotational force to be transferred to another gear. The gear teeth allow force to be fully transmitted without slip and depending on the configuration can transmit forces at different speeds, torques, and even in different directions. In bevel gear, a tangential load and static load are formed due to the speed and torque. This will be a transient phenomenon and need careful stress analysis for determining the life of the gears. In automobiles and other wheeled vehicles, the differential unit allows each of the driving wheels to rotate at different speeds, while most vehicles supplying equal torque to each of them.

This research needs structural analysis for defining the better replacement material for cast iron in crown pinion gears. Various researchers have studied and tested the crown pinion, some of them are taken as references for this work. Hari Babu and Durga Prasad [1] concentrated on making changes to mitigate differential errors. The CATIA V5 software was used to design and analyse the differential crown wheel and pinion made of G-45 steel inside an Ashok Leyland tipper, as well as the geometric model of the pinion and crown wheel of the rear axle differential. The differential gears assembly and its housing was analysed for vibrational effects on a device in which the life of the gears is calculated over a wide frequency range using Ansys-14.0 platform. Shashank Pandey et al. [2] compared the

\* Corresponding author.

E-mail address: [charles7esmee@gmail.com](mailto:charles7esmee@gmail.com) (R.Charles Godwin).

<https://doi.org/10.1016/j.jmrt.2021.10.056>

2238-7854/© 2021 Published by Elsevier B.V. This is an open access article under the CC BY-NC-ND license (<http://creativecommons.org/licenses/by-nc-nd/4.0/>).

obtained results to AGMA theoretical stress values and found that the results are strongly consistent with the observed values, implying that the model constructed is accurate.

Hari Babu and Durga Prasad [3], have calculated von misses stress in the pinion is 210.5N/mm<sup>2</sup> and the pinion has a deformation of 0.0682 mm. These stress values are lower than the overall stress value of 560 N/mm<sup>2</sup> (standard steel value) and deformations are even lower, 0.0682 mm under the actual torsional moment of 577500N-mm. According to Santosh S Bagewadi et al. [4], the current pinion is made of SAE 4130 steel and has been rebuilt using SAE 9310 steel as the pinion material. For 11 teeth, SAE 4130 steel content has a margin of protection of 0.57. The calculations are performed using SAE 9310 steel, which has a margin of protection of 0.68 for ten teeth. Even after reducing one tooth on the pinion, the margin of safety is high. The pinion's weight is therefore reduced by reducing the number of teeth.

The structural analysis outcomes using Aluminium alloy have been found by Veeranjanyulu and Hari Babu [5], and the stress values are within the allowable stress value. As the stress values of the three components are compared at all speeds (2400 rpm, 5000 rpm, and 6400 rpm), the Aluminium alloy has lower values than Alloy Steel and Cast Iron. Since its normal frequency is lower than the other two

materials, the vibrations for Aluminium Alloy are lower than the other two materials. In addition, since the density of aluminium alloy is much lower than that of alloy steel and cast iron, the weight of the alloy is almost three times lower. Siva Teja [6] used a frictional contact of 0.2 between the mating gears to see if the frictional contact has an impact on the load. According to the findings and diagrams, grey cast iron and aluminium alloy are both preferable for the use of differential gears in automobiles. However, when it comes to weight, Aluminium Alloy is desired for light utility vehicles.

The assembly of crown gear and pinion have been designed by Satypal et al. [7], in CATIA and analysed in ANSYS 15.0 Software by selecting various materials. Based on Finite Element Analysis (FEA), it is concluded that the Grey Cast Iron assembly of crown gear and pinion is most useful as compare with other material assemblies. Since the maximum stress in pinion is 157.5 MPa and in gear is 315.34 MPa. Also, the total deformation in assembly is 0.09 mm. Praveen Kumar Tiwari et al. [8], have started to analyse and validate the stress distribution in bevel gears using the contemporary FEM program and ANSYS 14.0. The gear housing design should provide a technique for dealing with causes that induce vibrations, as well as scientific methods for reducing the influence of frequencies. Mayank Bansal et al. [9] performed mechanical configuration and

**Table 1 – Physical and mechanical properties of proposed material.**

Description	Cast Iron	Low Carbon Steel	High Carbon Steel	Silicon Carbide
Density (g/cc)	7.22	7.6	7.54	3.18
Young's modulus (GPa)	147	202	200	470
Poisson ratio	0.287	0.29	0.292	0.36
Thermal conductivity (W/m.K)	26.6	49.6	45.9	110
Tensile strength (MPa)	428	519	896	–

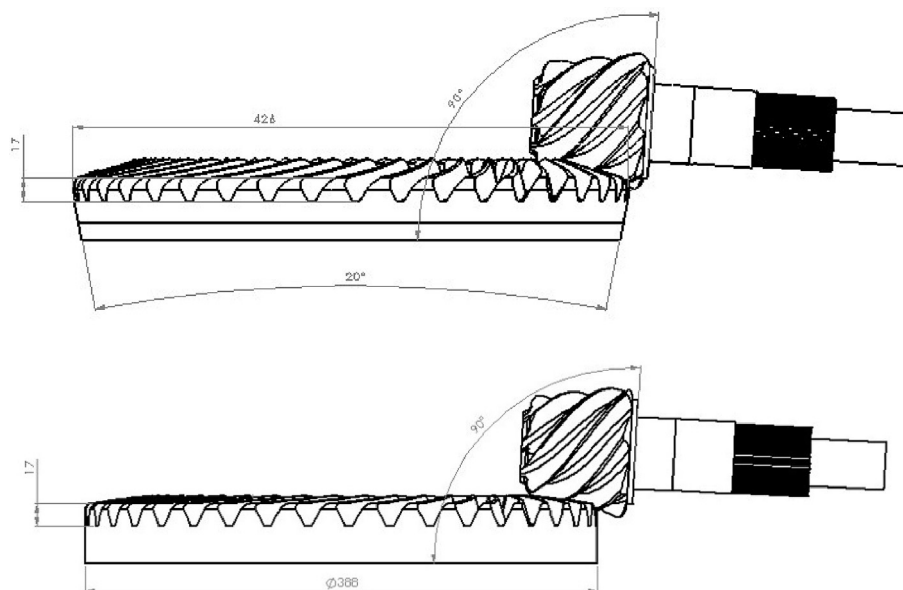

**Fig. 1 – Design parameters of crown pinion with and without elevation.**



Fig. 2 – CAD Design of Crown Pinion using Solid Works Software.

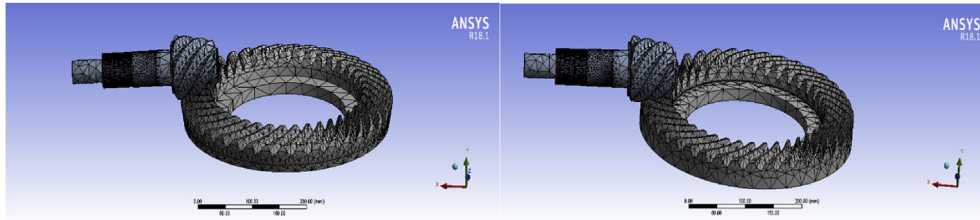

Fig. 3 – Mesh Generation Image of Crown Pinion using ANSYS Software.

interaction research on gearbox assembly while transmitting power at different speeds of 2400 rpm, 5000 rpm, and 6400 rpm by varying the different materials for gears on the differential of Ashok Leyland 2516M by varying materials and speeds. In CREO 3.0, differential gear is modelled. The structural behaviour under the given loading conditions was determined using the ANSYS 14.0 FEM software as the analysis method.

From the above exhaustive study, found that the researchers have used the finite element method and various solutions can be formed and upgraded to save energy by weight loss, improve wear protection and provide a longer

lifespan. The use of composite materials, which provides a solution to several difficulties in modern gears. As a result, this research focuses on using computer-aided engineering to replace present mechanical gear with metal matrix composite material gear to reduce weight and enhance the dependability of mechanical equipment.

## 2. Methodology and material selection

The main aim of the project is to verify the best material for the crown pinion gears in the differential at higher

Table 2 – Results of the crown pinion with elevation at static load condition.

Description	Deformation (mm)	Equivalent strain	Equivalent stress (MPa)	Normal strain	Normal stress (MPa)
Cast iron	0.026626	0.00041667	57.524	5.43E-05	21.965
Low carbon steel	0.019419	0.0003046	57.646	3.85E-05	21.432
High carbon steel	0.019484	0.00030364	57.295	4.19E-05	22.973
HCS + SiC(99.5 + 0.5)	0.019404	0.00026946	57.431	4.04E-05	22.376
HCS + SiC(99 + 1)	0.019273	0.00030105	57.425	4.02E-05	22.402
HCS + SiC(98.5 + 1.5)	0.019143	0.00029899	57.419	4.00E-05	22.429
HCS + SiC(98 + 2)	0.019015	0.00029696	57.413	3.98E-05	22.455
HCS + SiC(97.5 + 2.5)	0.018889	0.00029496	57.407	3.96E-05	22.481

Table 3 – Results of the crown pinion with elevation at tangential load condition.

Description	Deformation (mm)	Equivalent strain	Equivalent stress (MPa)	Normal strain	Normal stress (MPa)
Cast iron	0.0031602	0.00010176	13.138	1.23E-05	3.8894
Low carbon steel	0.0023046	7.41E-05	13.146	9.00E-06	3.8329
High carbon steel	0.0023131	7.47E-05	13.123	8.97E-06	3.9959
HCS + SiC(99.5 + 0.5)	2.30E-03	7.42E-05	13.132	8.95E-06	3.9329
HCS + SiC(99 + 1)	0.0022877	7.37E-05	13.132	8.89E-06	3.9357
HCS + SiC(98.5 + 1.5)	0.0022723	7.32E-05	13.131	8.83E-06	3.9385
HCS + SiC(98 + 2)	0.0022571	7.28E-05	13.131	8.77E-06	3.9413
HCS + SiC(97.5 + 2.5)	0.0022422	7.23E-05	13.131	8.71E-06	3.9441

**Table 4 – Results of crown pinion without elevation at static load condition.**

Description	Deformation (mm)	Equivalent strain	Equivalent stress (MPa)	Normal strain	Normal stress (MPa)
Cast iron	0.027498	0.00052653	70.917	6.25E-05	24.392
Low carbon steel	0.020061	0.00038527	71.341	4.44E-05	23.806
High carbon steel	0.020112	0.00038306	70.132	4.80E-05	25.505
HCS + SiC(99.5 + 0.5)	0.020036	0.0003828	70.594	4.65E-05	24.845
HCS + SiC(99 + 1)	0.0199	0.00038015	70.574	4.62E-05	24.874
HCS + SiC(98.5 + 1.5)	0.019766	0.00037753	70.553	4.60E-05	24.903
HCS + SiC(98 + 2)	0.019633	0.00037495	70.533	4.57E-05	24.933
HCS + SiC(97.5 + 2.5)	0.019503	0.0003724	70.512	4.55E-05	24.962

**Table 5 – Results of crown pinion without elevation at tangential load condition.**

Description	Deformation (mm)	Equivalent strain	Equivalent stress (MPa)	Normal strain	Normal stress (MPa)
Cast iron	12.383	0.0084481	843.57	3.27E-03	481.17
Low carbon steel	9.021	0.006203	851.09	2.38E-03	481.32
High carbon steel	9.0835	0.0061058	829.66	2.40E-03	480.88
HCS + SiC(99.5 + 0.5)	9.0335	0.0061255	837.84	2.39E-03	481.06
HCS + SiC(99 + 1)	8.9729	0.006082	837.48	2.37E-03	481.05
HCS + SiC(98.5 + 1.5)	8.913	0.0060391	837.12	2.35E-03	481.04
HCS + SiC(98 + 2)	8.854	0.0059968	836.75	2.34E-03	481.03
HCS + SiC(97.5 + 2.5)	8.7957	0.005955	836.39	2.32E-03	481.03

load by analysing stress, displacement and also by considering weight reduction. FEM Analysis is carried out for different composition of high carbon steel and silicon carbide materials. The general procedure of FEA which includes material selection, CAD modelling, meshing, boundary condition and solution are discussed as follows.

A composite material is made up of two or more components based on their physical and chemical properties. The additive materials are mixed together to create a composite with properties that differ from the parent individual components. The bonding parameters of each substance such as temperature, boiling point, and melting point, are used to choose composite materials. The

proposed material for Crown and pinion has been selected based on the study of material characterisation and its standard. The composition of high carbon steel and silicon carbide materials have proposed to crown and pinion gears because of high creep resistance, high toughness, fatigue strength, low von-misses stress, high impact strength, less deformation, and increased lifetime. On basis of the characteristics and properties of each material is discussed below.

**2.1. Cast iron**

One of the oldest ferrous metals used in building and outdoor ornament is cast iron. It's tough, porous, non-

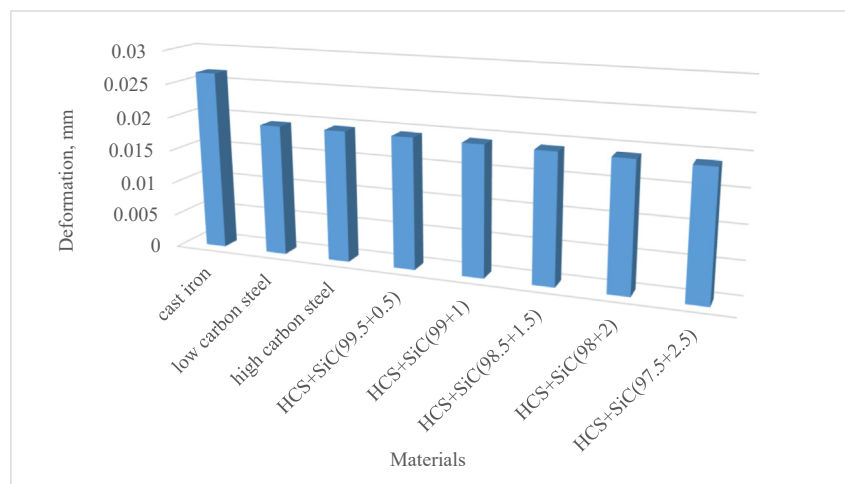

**Fig. 4 – Deformation comparison of different materials for crown pinion with elevation (static loading).**

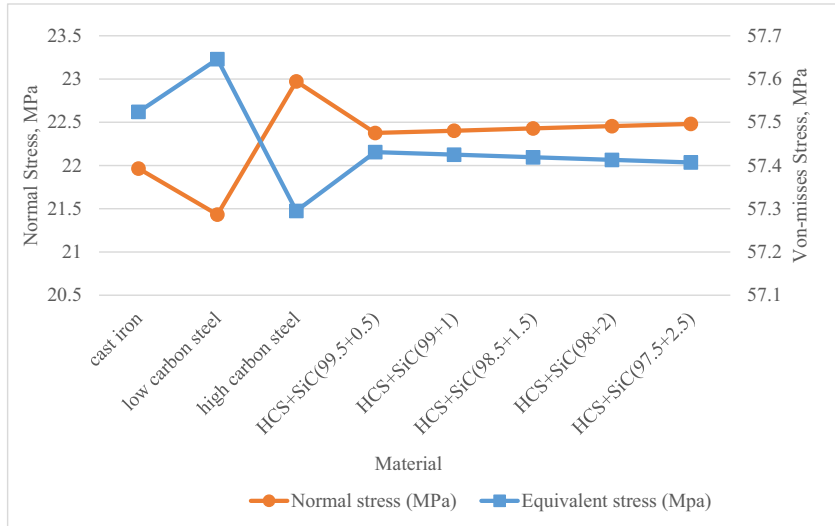

Fig. 5 – Comparison of Stresses by different Material for Crown Pinion with Elevation (Static Loading).

malleable (meaning it can't be twisted, drawn, or pounded into shape), and more fusible than concrete. It has a crystalline composition and fractures when subjected to high tensile loads with no distortion. Cast iron's structure and manufacturing process are crucial in deciding its properties.

2.2. Low carbon steel

Low carbon steels have a wide range of uses. This kind of steel can be used after carburizing for wear resistant goods with poor or inferior mechanical properties (small shafts, plunges, or highly loaded gearing). Since they contain very little carbon, normally less than 0.10 percent C, and up to 0.4 percent Mn, these steels have a high formability.

2.3. High carbon steel

High-carbon steel is described as steel with a carbon content of 0.55 percent or more. While this is how cast-iron items (wood stoves, cookware) are produced, pushing this material beyond 2% makes the result highly fragile and of little use. Quite high strength, intense stiffness and wear resistance, and reasonable ductility, an indicator of a material's ability to withstand being deformed without eventually cracking, are all characteristics of high carbon steel.

2.4. Silicon carbide

The most commonly used source for structural ceramics has been silicon carbide. Low thermal expansion, a large force-to-

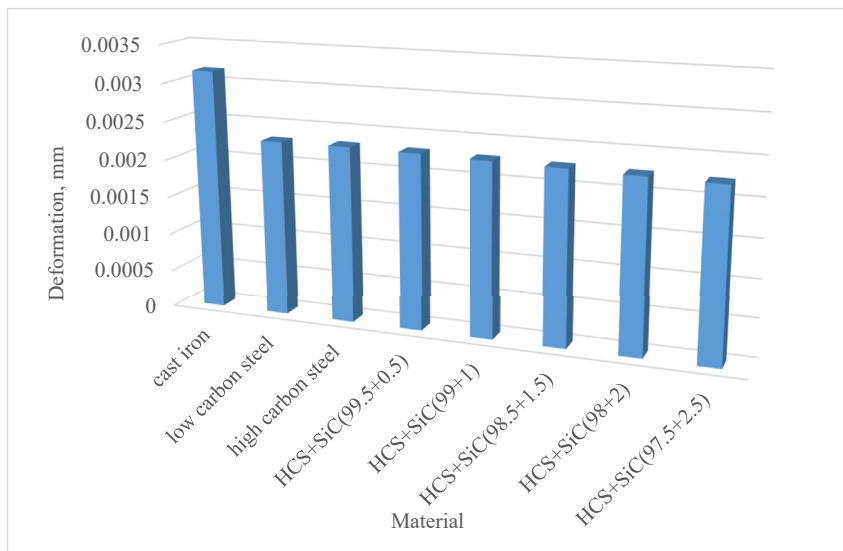

Fig. 6 – Deformation comparison of different materials for crown pinion with elevation (tangential loading).

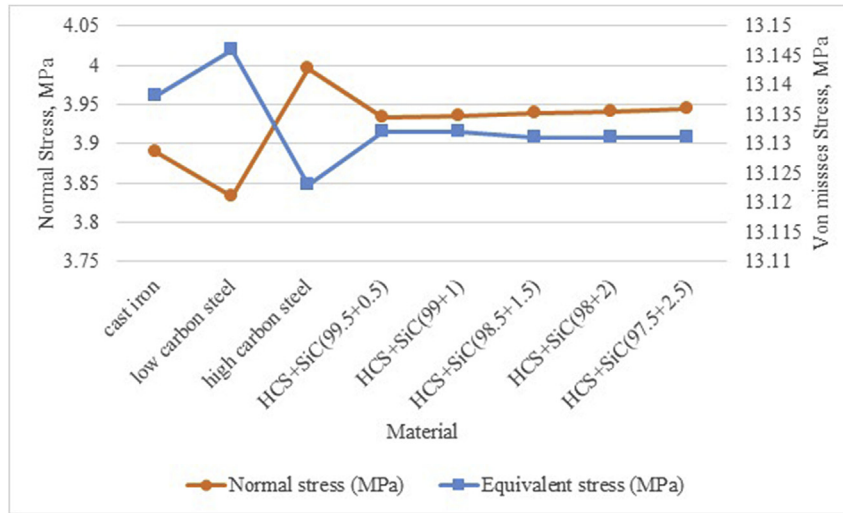

Fig. 7 – Comparison of Stresses by different Material for Crown Pinion with Elevation (Tangential Loading).

weight radius, high thermal conductivity, hardness, abrasion and corrosion resistance, and, most notably, the ability to maintain elastic resistance at temperatures up to 1650 °C have contributed to a wide variety of applications.

The project's key purpose is to examine which material is best for the crown and pinion gears in the differential at higher loads by studying stress, displacement, and weight reduction. Variations in the formulations of high carbon steel and silicon carbide compounds for gears are used to do an investigation.

Table 1 represents the physical and mechanical properties of proposed material for crown pinion gears. Among these materials, different proportions have been chosen to optimize by the FEA analysis of crown pinion are as follows:

- High carbons steel (99.5%) + Silicon carbide (0.5%)
- High carbons steel (99%) + Silicon carbide (1%)
- High carbons steel (98.5%) + Silicon carbide (1.5%)
- High carbons steel (98%) + Silicon carbide (2%)
- High carbons steel (98.5%) + Silicon carbide (2.5%)

### 3. Finite element analysis

The ANSYS software is used as analytical tool to determine the structural behaviour of various material compositions of high carbon steel with silicon carbide under defined loading circumstances. Crown and pinion gears are modelled by using SOLIDWORKS and imported in ANSYS to perform with conditions of tangential and static load. The manual design parameters have derived to generate CAD model of crown pinion

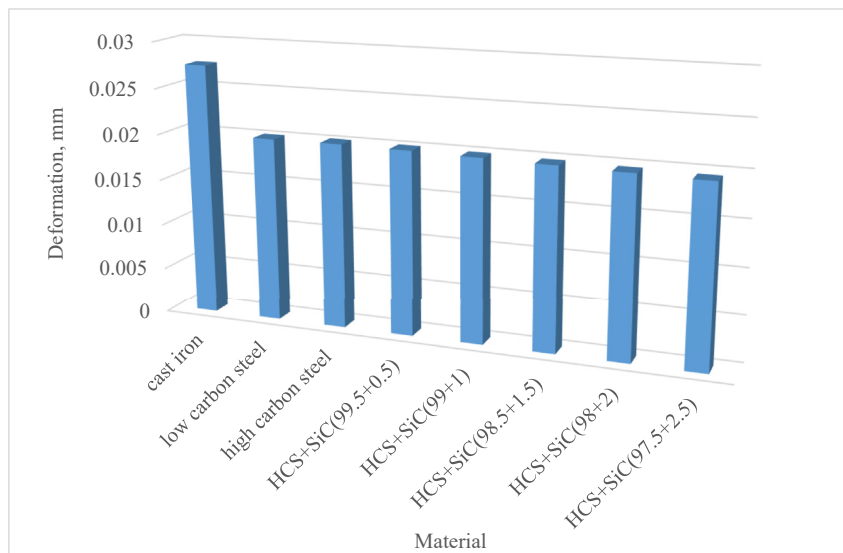

Fig. 8 – Deformation comparison of different materials for crown pinion without elevation (static).



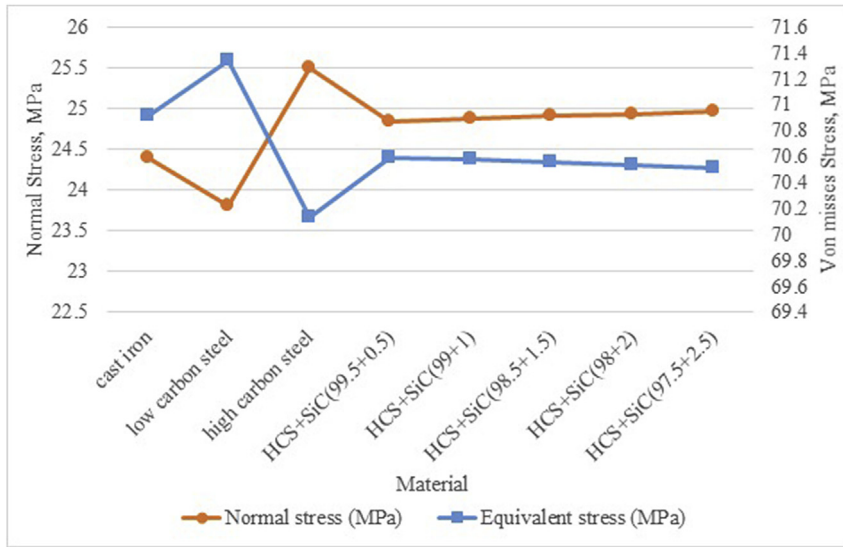

Fig. 9 – Comparison of Stresses by different Material for Crown Pinion without Elevation (Static).

based on American Gear Manufacturer Association (AGMA) standard which is shown in Figs. 1–3. The parameters include pitch circle diameter, pitch cone distance, pitch angle and module etc., which represents through formulas 1–8.

**Model Assumptions:**

- Pressure angle ( $\alpha$ ) = 20°
- Gear arrangement = 90°
- Pitch cone angle ( $\phi$ ) = 45°
- Back cone angle ( $\beta$ ) = 45°
- Module (M) = 11.
- Number of teeth on crown gear = 40.

Number of teeth on pinion = 6.

**Design calculation of crown and pinion gear:**

Pitch circle diameter (D)

Crown ( $D_g$ ) = 426

Pinion ( $D_p$ ) = 77

Number of tooth on gear

Crown ( $Z_g$ ) = 39

Pinion ( $Z_p$ ) = 7

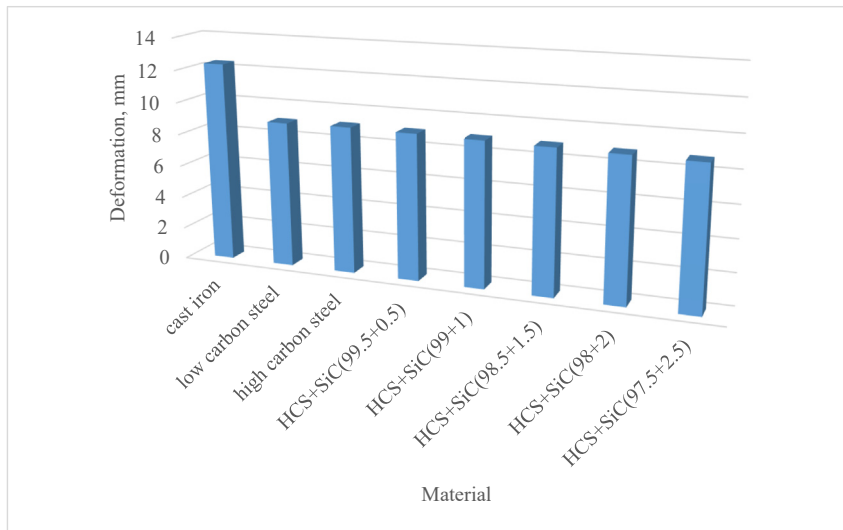

Fig. 10 – Comparison of material deformation by different material for crown pinion without elevation (tangential).

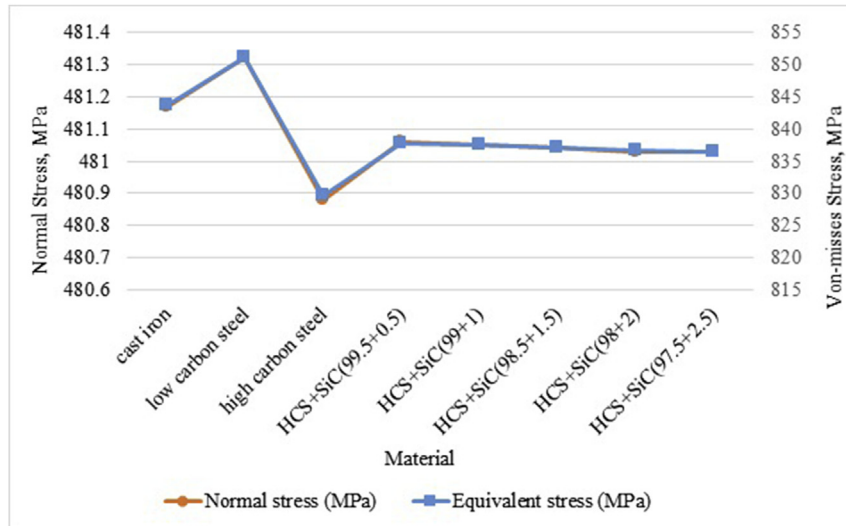

Fig. 11 – Comparison of stresses by different material for crown pinion without elevation (tangential).

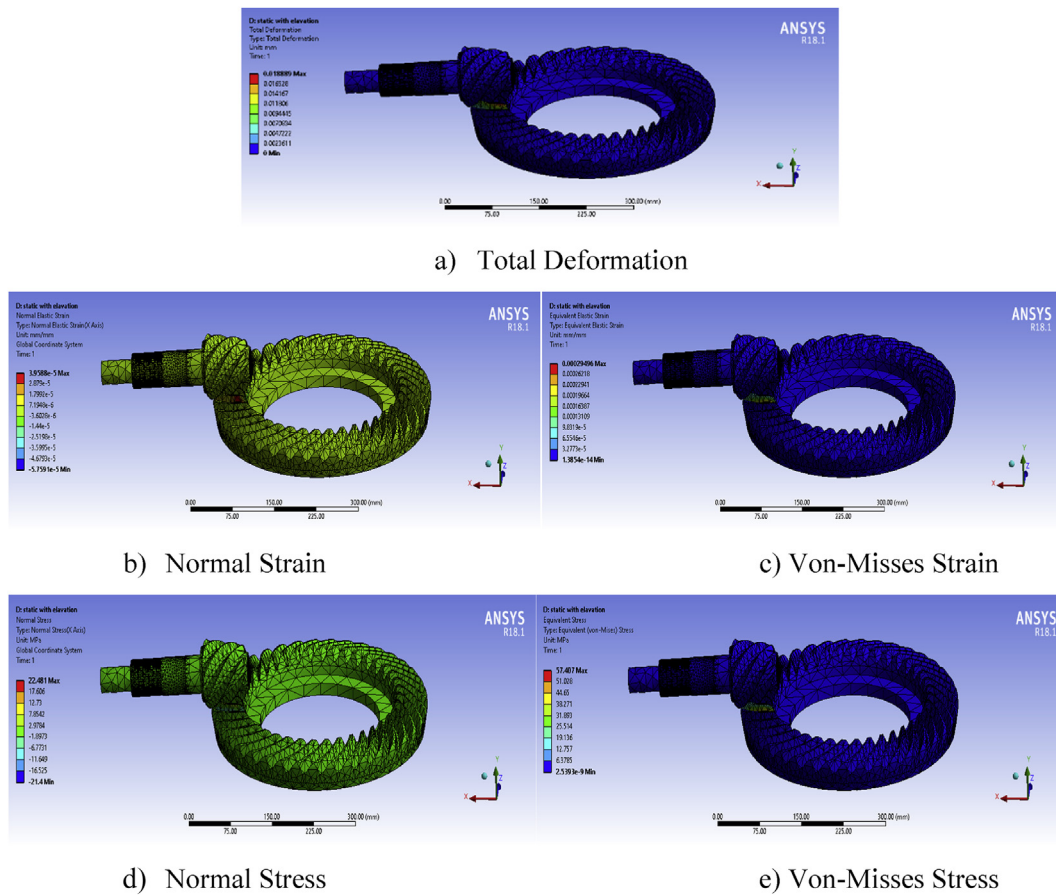
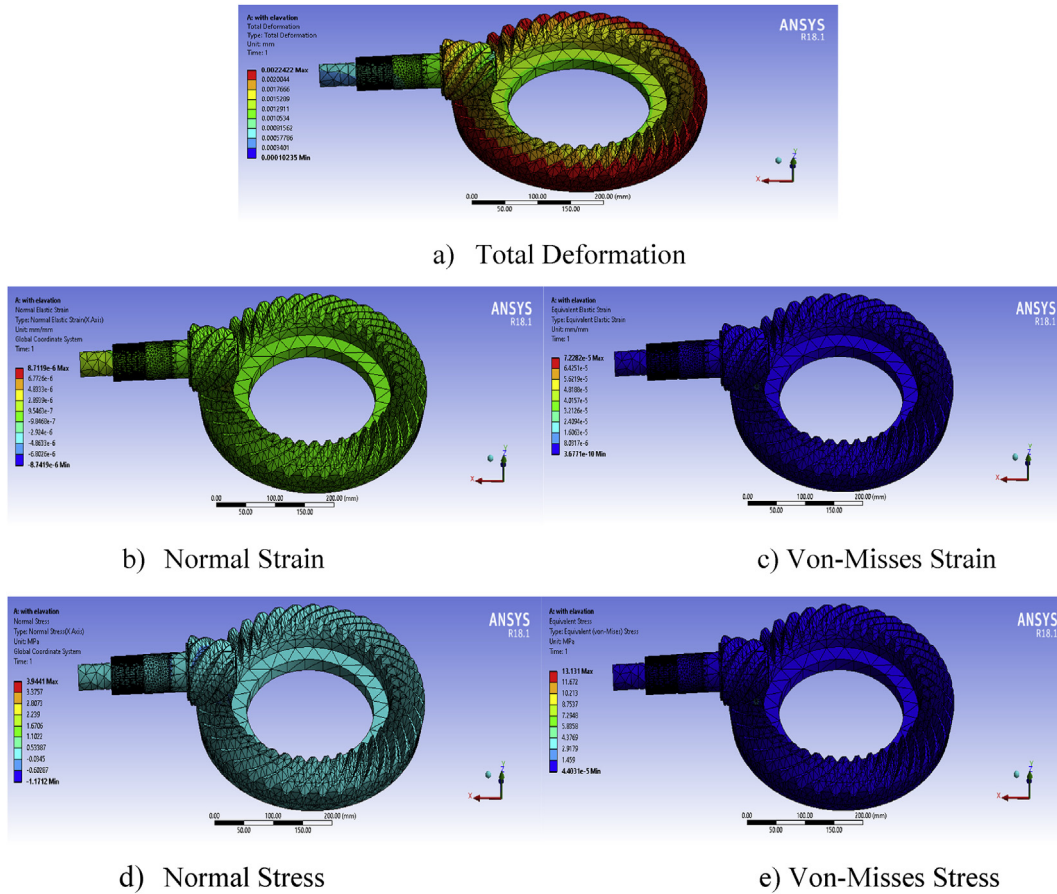

Fig. 12 – FEM results of crown pinion with elevation for the tangential loading condition.





**Fig. 13 – FEM results of crown pinion with elevation for the static loading condition.**

$$D = D_g + D_p \tag{1}$$

$$T = Z_g + Z_p \tag{2}$$

$$\text{Module (M)} = D/T = 10.93 \tag{3}$$

$$\text{Velocity ratio (V.R)} = Z_g/Z_p = D_g/D_p = N_p/N_g \tag{4}$$

$$= Z_g/Z_p = 39/7 = 5.532.$$

$$5.532 = N_p/N_g$$

$$N_g \cdot 5.532 = 1500 \text{ rpm}$$

$$N_g = 271.12 \text{ rpm}$$

Pitch angle ( $\theta$ )

$$\text{Pinion } (\theta_p) = \tan^{-1} (1/V.R) \tag{5}$$

$$= \tan^{-1} (1/5.532)$$

$$= 10.17^\circ$$

$$\text{Crown } (\theta_g) = 90 - \theta_p \tag{6}$$

$$= 90 - 10.17$$

$$= 79.824^\circ$$

Pitch cone distance (AO)

$$AO = ((D_1/2)^2 + (D_2/2)^2)^{1/2} \tag{7}$$

$$= ((426/2)^2 + (77/2)^2)^{1/2}$$

$$= (45369 + 1482.25)^{1/2}$$

$$AO = 216.45 \text{ mm}$$

$$\text{Face width} = AO/3 \tag{8}$$

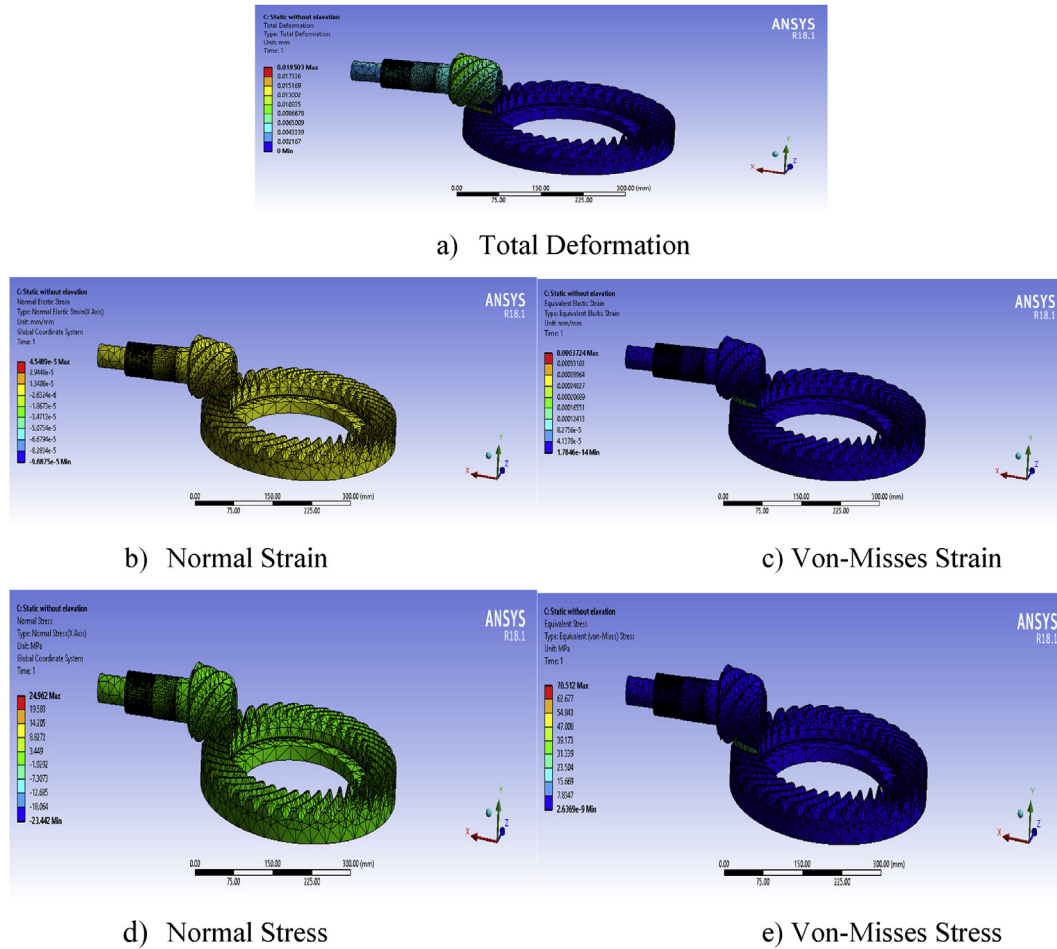

Fig. 14 – FEM results of crown pinion without elevation for the static loading condition.

$$= 216.45/3$$

$$= 72.15 \text{ mm}$$

#### 4. Results

When the crown is subjected to the following loads and constraints, the FEA findings from ANSYS software are as follows and the parameters are verified by design calculation of crown and pinion.

- Static Load applied = 21,000 N
- Tangential Load applied = 21,000 N-mm
- Number of 3D model used = 2 (with & without elevation)

The below tables show the obtained results from the structural analysis of crown and pinion gears for both

models with elevation and without elevation. Crown pinion with elevation results like deformation, von mises stress & strain, normal stress & strain are shown in Table 2 for each material at static load. The tangential load results are shown in Table 3. for crown pinion with elevation. The result for static load conditions as shown in Table 4. for crown pinion without elevation. Table 5 shows the results for tangential load condition at crown pinion without elevation.

The following images are the total deformations, normal stresses and von-mises stresses for both models (crown pinion with elevation and without elevation) have represented graphically from Figs. 4–11. These analysis output of crown gear and pinion gears at the boundary conditions of static and tangential loads.

From the structural analysis of crown pinion with and without elevation at static and tangential loading conditions, result images are shown in above figures (Figs. 12–15). The total deformation, normal strain, and von-misses strain,

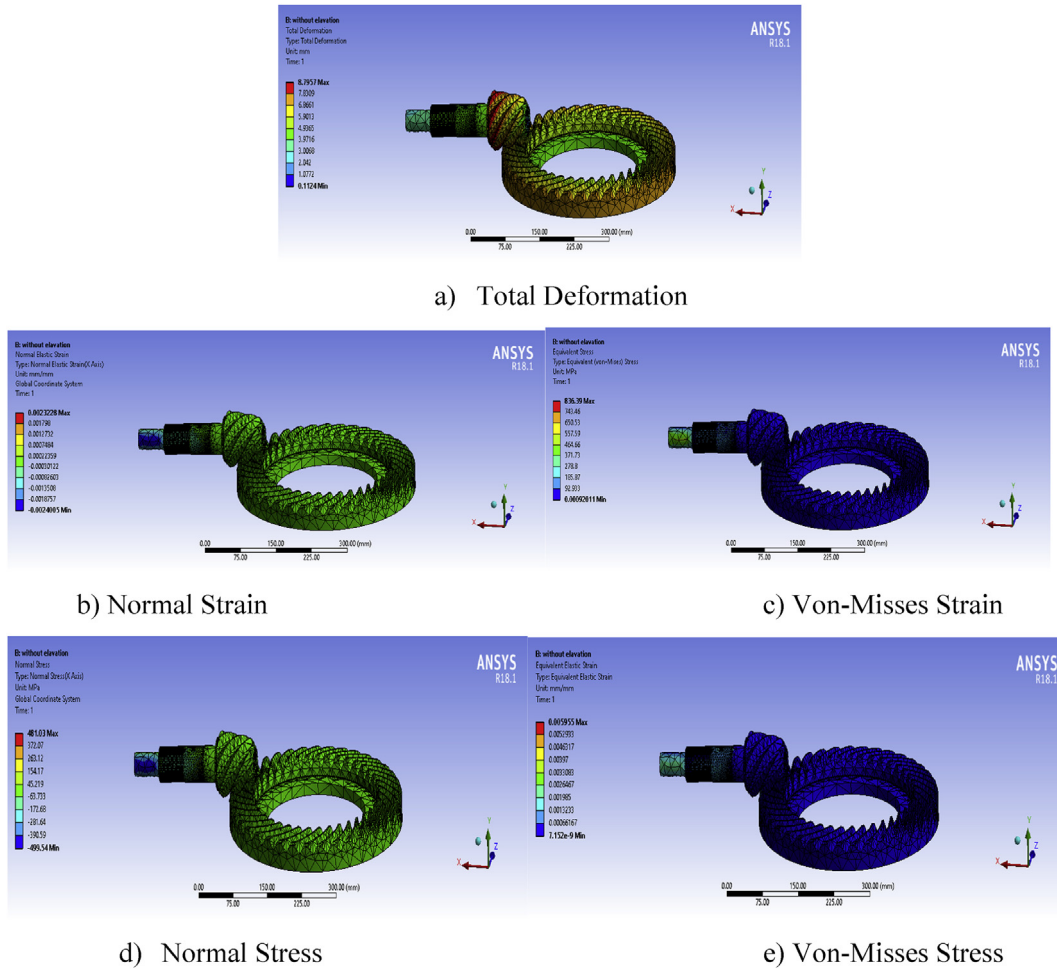

Fig. 15 – FEM results of crown pinion without elevation for the tangential loading condition.

Table 6 – Results of High carbon steel (97.5%) + Silicon carbide (2.5%).

High Carbon Silicon + Silicon Carbide (97.5% + 2.5%)					
Model	Deformation (mm)	Equivalent strain	Equivalent stress (MPa)	Normal strain	Normal stress (MPa)
Crown pinion with elevation (Static load)	0.018889	0.00029496	57.407	3.96E-05	22.481
Crown pinion with elevation (Tangential load)	0.0022422	0.0000723	13.131	8.71E-06	3.9441
Crown pinion without elevation (Static load)	0.019503	0.0003724	70.512	4.55E-05	24.962
Crown pinion without elevation (Tangential load)	8.7957	0.005955	836.39	2.32E-03	481.03

normal stress and von-mises stress have been observed. While considering the overall result, High carbon steel (97.5%) and silicon carbide (2.5%) seem to be better when comparing existing materials. In the above images displays the results for high carbon steel (97.5%) with silicon carbide (2.5%) material.

### 5. Conclusion

The investigation of the crown wheel and pinion aids to determining the cause of failure, emphasising the importance

of choosing the proper material and understanding the complexities of structural analysis. The existing crown pinion is redesigned by considering alternate material of high carbon steel with silicon carbide at the ratios of 99.5:0.5, 99:1, 98.5:1.5, 98:2 and 97.5:2.5 percentages respectively. The obtained results of better outcome by finite element analysis are tabulated in Table 6 and summarized as follows. The composition of high carbon steel (97.5%) + silicon carbide (2.5%) performs better capability to withstand maximum load by its deformation and equivalent stress. So, this material can be considered as a suitable replacement for crown pinion gear to improve its lifespan.

---

### Declaration of Competing Interest

The authors declare that they have no known competing financial interests or personal relationships that could have appeared to influence the work reported in this paper.

---

### REFERENCES

- [1] Hari Babu AV, Durga Prasad B. Design and analysis of pinion & crown for the differential. *Mater Today: Proceedings* 2019;16.
- [2] Pandey Shashank, Singh NikhileshN, Sinha Prabhat Kumar. Modeling, design & analysis of differential gear box and its housing through FEM, Solid work & Ansys benchwork 14.0. *Int J Eng Sci Res Technol* 2017;6(9).
- [3] Hari Babu AV, Durga Prasad B. Failure analysis of rear axle differential pinion shaft. *Int J Pure Appl Math* 2017;117(10).
- [4] Bagewadi SantoshS, Bhavi IG, Kurbet SN. Design and analysis of crown pinion of a differential gear box for reduced number of teeth to improve torque transmitted. *Int J Mech Eng Robot Res* 2014;3(4).
- [5] Veeranjanyulu C, Hari Babu U. Design and structural analysis of differential gear box at different loads. *Int J Adv Eng Res Stud* 2012;1(2).
- [6] Siva Teja N. Design and analysis of differential gear box in automobiles. *Int J Mech Eng Technol* 2017;8(5).
- [7] Warghat SatypalT, Astonkar DhirajV, Bijwe ManishP. Analysis of differential crown gear and pinion for axle with different materials. *Int J Sci Develop Res* 2019;4(4).
- [8] Tiwari Praveen Kumar, Singh NikhileshN, Sinha Prabhat Kumar. Modeling, design & analysis of straight bevel gear and pinion by FEM, Solid works & Ansys bench work 14.0. *Int J Eng Manag Res* 2017;7(4).
- [9] Bansal Mayank, Sindhu Nidhi, Anand Santosh. Structural and model analysis of a composite material differential gearbox Assembly. *Int J Eng Sci Res Technol* 2016;5(6).

**Charles Godwin** is a Ph.D. research scholar in mechanical engineering at Vels University. Worked as an Assistant professor in Rajas engineering college. Participated in international conference on material modelling and manufacturing ICMMM 2017 held at VIT University.