

Precision Agricultural System for Crops Water Management using IoT

¹K.Sasikala, ^{2*}D.Ravikumar, ³Kishore Ragnath S, ⁴M.Karthikeyan, ⁵S.Ramesh, ⁶Sajeevram Arumugam

¹*Department of Electrical and Electronics Engineering, Vels Institute of Science, Technology & Advanced Studies, (Vels University) Chennai, India.*

^{2,3,4}*Department of Electronics and Communication Engineering, Vels Institute of Science, Technology & Advanced Studies, (Vels University) Chennai, India.*

⁵*Department of Electronics and Communication Engineering, SRM Valliammai Engineering College, Chennai, India.*

⁶*Department of Information Technology, Sri Krishna College of Engineering & Technology, Coimbatore, India.*

Abstract

Agriculture drives as a vital thing in the world by meeting one of the elementary needs of an individual human. The Internet of Things (IoT) has set a goal in the technologies and has become a support to agriculture. This development in technology useful in farming automation, which aids in influential in farmer's workspace, ensuring them with device management, connectivity management, and production as a result along with secluded management. Water shortages diminish vegetable growth and wetness pressure affects the growth of plant tissues, which in turn can have very deep effects on vegetable growth. Environmental influences strong high among those that regulate vegetative progress and among these environmental factors, soil temperature, and water play important roles. In this article, we present an IoT based precision agricultural system for crops water management for operative yield in agriculture.

Keywords: *Internet of Things, Water Management, Agriculture, Precision Irrigation, ARM Processor, Wi-Fi module, Wireless technologies.*

1. Introduction

The internet has endured a radical progress in the last two decades. The IoT is prearranged to the connected physical devices on the internet. Rendering to [1, 2] there will be 60 billion things linked to each other through the internet everywhere the globe by the year 2022. The IoT technology with embedded systems wherein devices are connected to the internet consists of transducers, sensors, actuators and network connectivity used to meet and exchange information among them. In the area of smart agriculture, the IoT plays a key role. In India, agriculture is the dominant prime for the people for their existence. Due to the shortage of farmers and the lack of suitable agriculture systems, they depend upon rainfall. Agriculture requirements are growing daily due to the huge growth in the population. Agriculture is the backbone of India, yet it is the field which is facing difficulties [3]. The impression of smart farming and gathering information about their corresponding agriculture fields with the help of sensors and actuators.

Agriculture is the greatest substantial sources of the economy of the world. In India above 80% of the population depends on agriculture for their survival [4]. Many farmers have been used predictable methods for farming, which provides small results about yield crops and plant growths, which flags the path for agriculture automation in areas such as irrigation, cultivating, spreading, and reaping, pesticides spewing. The IoT can mostly play a vital role in the agricultural field such as water management, crop monitoring, soil

management and control insecticides and pesticides [5]. The progress in diverse technologies [6, 7] such as physical, tractors and machineries, computers, information technology, satellite and sensor, mobiles and database software's to IoT, big data, and artificial intelligence in the era from before 2000 to at current time respectively. Rendering to the UN food and agriculture organization, the world needs to harvest more than 80% of food in 2020 as compared to 2013. To attain this and also for improved production farmers [8] and agriculture companies are touching into technologies like IoT, artificial intelligence. Henceforth smart agriculture and sophisticated crop production will help farmers to meet this growth in food demand.

The IoT is shifting in the agriculture areas like study of diseases, adjustable of fertility, water stress, field watching, soil erosion, smart data, crop yield investigation and auto dispersion. The role of IoT in agriculture as shown in below Figure 1. In this work, we propose a precision agriculture system for live monitoring of temperature and soil moisture which purposes in water preservation and yield in agriculture.

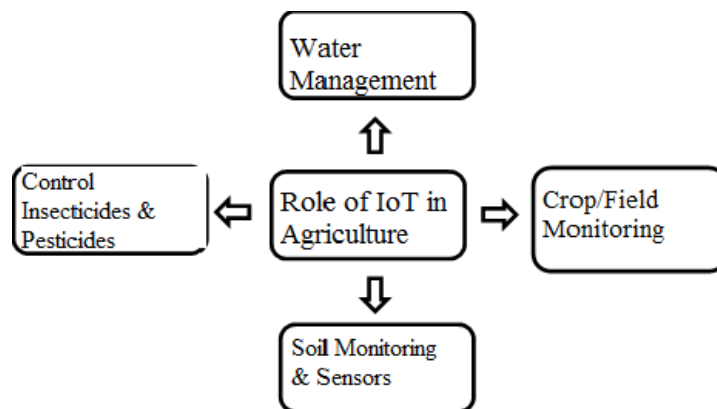

Figure 1. Role of IoT in Agriculture

2. Related Works

Currently the emerging technologies are playing a key role in the agriculture area with an automated system and realized numerous system designs for smart agriculture, precision agriculture and also drip irrigation. Respectable investigation is being done on agriculture. Few prevailing works are cited below.

In [9, 10] recommended the IoT and agriculture statistics investigation for the smart farm. The author discoursed the three towns, with their farming in terms of crop harvest and water management by IoT devices. Upon getting the agriculture field evidence, it is passed through an internet and a mobile application with the assistance of node MCU with the Wi-Fi module to the former. The system comprises of three sensors like a soil moisture sensor, a DHT22 sensor, and an ultrasonic sensor. The system has a squat cost. A smart agriculture scheme in India using the IoT established [11]. Farmers have committed suicide due to trivial crop harvest and unpaid loans. To overcome the problems, IoT based smart agriculture system with diverse sensors and Raspberry Pi board and also proposed effective food corporations of India with the direction of pests and soil moisture, structure intelligent seeds are used to flow yield. Though, the design of the system is very vigorous but high cost.

The authors [12] projected a scheme for smart agriculture with the assistance of different types of sensors like soil moisture, temperature, humidity and water level pointer. These sensors are linked to an ARM 7 processor, which will add the analyzed data and lead it to the cloud network. Through the Wi-Fi module only, the data will be established by the farmer on mobile. Here four sensors are interfaced with ARM 7 which is additional

robust when associated to the other boards. In [13] presented an evaluation on cloud of things for smart agriculture. This exemplary gives the comprehensive information regarding the finding of rodents that changed the yield of crops over the incorporation of cloud and IoT using triple tier architectures namely back-end layer, gateway, and also front-end layer. Numerous constraints are determined by the sensors such as temperature, humidity and moisture sensors values respectively are shown on board. The triple tier architecture was executed with high cost using layers.

The authors [14] suggested a concept on governing and checking the plant growth conditions using embedded systems. The system eases in checking the plant growth effectiveness with the tremendous working conditions beside with cost effectiveness which marks the farming easier. Various landscapes such as temperature, pH level, moisture level, and light intensity are accountable for plant growth. Interfacing of all the sensors to the Raspberry Pi model B, and also it has a huge cost. The main yield of this system is used more sensors. In [15] performed a design on the determination of soil moisture by various sensors for irrigation water management. This system comforts in irrigation and precision farming methods with resistive and capacitive soil moisture sensors. Soil moisture can be restrained by the foreseeable oven method with water content. Here assessment of resistive and capacitive moisture sensor values determines the soil moisture for irrigation of water management. The hardware execution had used Arduino Uno board with a moisture sensor with the help of mathematical modeling.

3. Solution Description and Results Discussion

The proposed precision agricultural system for crops water management using IoT is shown in Figure 2.

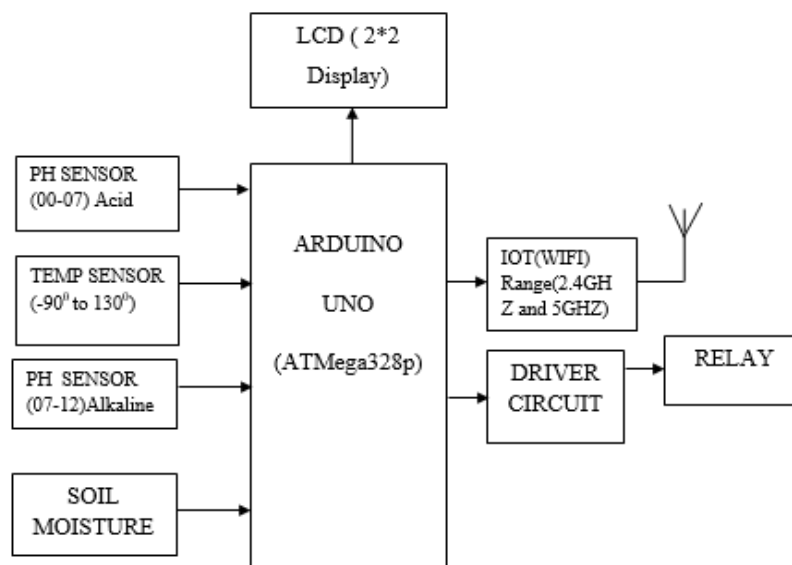

Figure 2. Precision Agricultural system using IoT

Data are collected in the programmed irrigation process via sensors as shown in Figure 2 and irrigation activates more sensibly than the irrigation process in real time, as in some cases, if there are no wireless connections, these data are not consistent on a real-time event. Figure 3 describes the overview of the system employing the internet of things and sensor cloud.

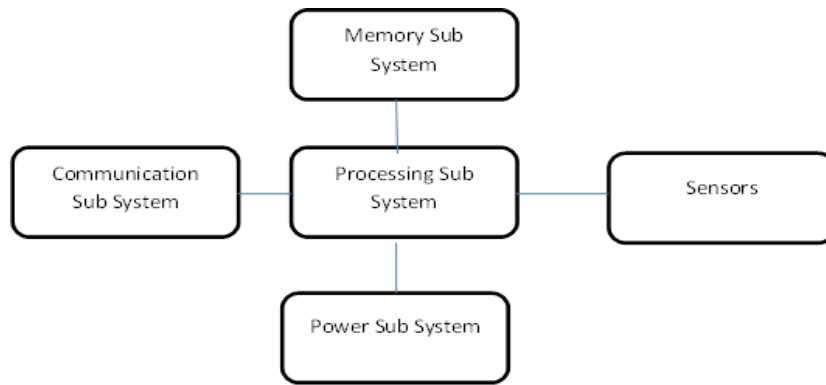

Figure 3. System using IoT and Sensor Cloud

The neighboring plants make a noteworthy impact on the wireless transmitters, and they desired to be situated above the top of the plants to evade signal attenuation. The smart sensor boards were powered with a 9 V battery that was intelligent to provide power during the whole crop's growing period, performing sensor measurements and data transmission each hour in that period[16]. A thermistor is a kind of device whose resistance varies with temperature. Thermistors are extensively used as temperature sensor. A humidity sensor measures and repeatedly reports the qualified humidity in the air. Soil moisture sensors measure the water content in soil. A soil moisture probe is prepared up of multiple soil moisture sensors. pH sensor is used for measure of acidity and alkalinity, or the caustic and base existing in water. It is commonly expressed with a numeric scale ranging from 0-14. The value 7 signifies neutrality. The numbers on the scale rise with increasing alkalinity, while the numbers on the scale decline with increasing acidity. Each unit of change signifies a tenfold change in acidity or alkalinity.

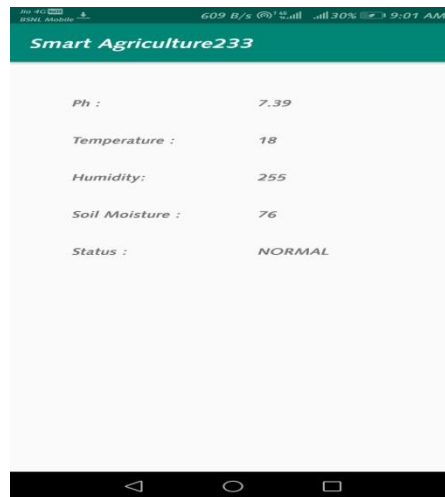

Figure 4. Moisture level of Soil using pH Sensor (Normal)

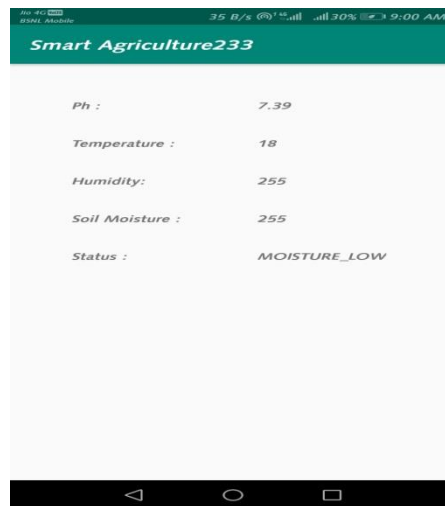

Figure 5. Moisture level of Soil using pH Sensor (Low)

The experimentation was considered to determine the impact of the pond on soil moisture and if the ponding is optimum, peak soil humidity is unchanging. The experiment was also perceived to fix the impact on soil humidity and the pitch of the parts. The question was also whether irrigation persuaded a distinction in soil moisture uniformity. Plants always need necessity water because of different conditions. The alterations in the temperature, leave wet, soil moisture or the hazard of disease can determine these circumstances. The irrigation control system is activated by this variation to begin an irrigation incident, which uses the collected sensor nodes. The Figure 4 shows moisture level of soil by using pH sensor. When it normal the water pump will be in OFF stage. The Figure 5 shows that moisture level is low. Then the water pump will be turn ON automatically.

The monitoring can be carried out straight via user orders from ubiquitously or by means of a programmed method placed by a moment interval clock during different phases, which is more self-governing of being interacting in real time with the radio system. The scheduled irrigation process using sensors to collect data, then start irrigation its more accountable than the real-time irrigation process, because if there is no radio connection in case of some glitches this data at the real time event is not reliable. The proper water management indications to higher conductivity and improves soil moisture. The experiment was also intended to govern the effect crop cover, and resulting soil moisture consistency. Another factor deliberated was whether irrigation caused a difference in the consistency of soil moisture. The consequence of soil temperature and soil water force on the rate of growth and rate was witnessed. Proper management of water pays to increased conductivity and improves humidity in the land.

4. Conclusion

The IoT based precision agriculture system for live monitoring of temperature and soil moisture has been proposed in this article using Arduino and cloud computing. Suitable management of water pays to increased conductivity and progresses humidity in the land. Another deliberation was whether irrigation shaped a difference in groundwater moisture uniformity. The system has high efficiency and accuracy in fetching the live data of temperature and soil moisture. It will assist farmers in increasing the agriculture yield and take efficient care of food production and providing support to farmers. By relating appropriate agricultural technologies such as wireless sensor networks, this will not only upsurge resources enlistment but also ease and encourage public cum private firms'

access to real transfer growth to the agriculture as a foremost of the cause of income in the agriculture reliant countries.

References

- [1] A. Bahga, M. Vijay, "Internet of things: A hands-on approach", VPT, New Delhi, (2015).
- [2] D. Singh, G. Tripathi, A. J. Jara, "A survey of internet-of-things: Future vision, architecture, challenges, and services", Proceedings of IEEE world forum on internet of things, Seoul, (2014), pp. 287–292.
- [3] K. Abhishek, K. Sanmeet, "Evolution of internet of things (IoT) and its significant impact in the field of precision agriculture", Computers and Electronics in Agriculture, vol. 157, (2019), pp. 218–223.
- [4] M. Lavanya, S. Srinivasan, "A survey on agriculture and greenhouse monitoring using IOT and WSN", International Journal of Engineering & Technology, vol. 7, (2018), pp. 673–677.
- [5] G. S. Reddy, C. M. Anuja, C. R. Manjunath, S. Shetty, S. "Smart agriculture by monitoring moisture pH levels in soil", International Journal of Advance Research, Ideas and Innovations in Technology, vol. 4, no. 3, (2018), pp. 408–411.
- [6] S. Ramesh, T. Rama Rao, "Indoor radio link characterization studies for millimeter wave wireless communications utilizing dielectric-loaded exponentially tapered slot antenna", Journal of Electromagnetic Waves and Applications, vol.29, no.4, (2015), pp. 551–564.
- [7] K. S. Arunlal, S. N. Rajkiran, "Smart agriculture: IoT based precise and productive farming approach", International Journal of advanced Research, Ideas and Innovations in Technology, vol.4, no.6, (2018), pp.771–775.
- [8] B. Basnet, J. Bang, "The state-of-the-art of knowledge-intensive agriculture: A review on applied sensing systems and data analytics", Journal of Sensors, vol. 2018, (2018), pp. 1–13.
- [9] M. Jirapond, B. Nathaphon, K. Siriwan, L. Narongsak, W. Apirat, N. Pichetwut, "IoT and agriculture data analysis for smart farm", Computers and Electronics in Agriculture, vol. 156, (2019), pp. 467–474.
- [10] S. Manoj, K. Sasikala and D. Ravikumar, "A Novel Technique for Protection of Motor and Generator Using Programmable Transducer", Journal of Advanced Research in Dynamical and Control Systems, vol.04, no.1, (2017), pp. 181–18.
- [11] G. V. Sai Prasanna, G. Vijay Kumar, "Controlling and monitoring the plant growth conditions using embedded systems", International Journal of Innovative Technology and Exploring Engineering, vol. 8, no.6, (2019), pp. 1552–1555.
- [12] B. Praveen, J. N. Patel, "Determination of soil moisture using various sensors for irrigation water management", International Journal of Innovative Technology and Exploring Engineering, vol. 8, no.7, (2019), pp. 557–582.
- [13] G. Anjali, B. Sagar, K. Shubhangi, "A review paper on effective agriculture monitoring system using IoT", International Journal of Modern Trends in Engineering and Research, vol. 5, no. 3, (2018), pp. 15–17.
- [14] K. Lova Raju, V. Vijayaraghavan, "IoT Technologies in Agricultural Environment: A Survey", Wireless Personal Communications, (2020), <https://doi.org/10.1007/s11277-020-07334-x>.
- [15] M. Jayalakshmi, V. Gomathi, "Sensor -Cloud based Precision Agriculture Approach for Intelligent Water Management", International Journal of Plant Production, vol. 14, (2020), pp.177–186.
- [16] K. Sasikala, D. Ravikumar, B. Rubini and Kathiresan, "Power Harvesting Using Piezoelectricity" Journal of Advanced Research in Dynamical and Control Systems, 04-Special Issue, (2017), pp.154–160.
- [17] Deepak Sharma, MIS Division, CSIR-Central Scientific Instruments Organization, Sector-30C, Chandigarh-160030(India).