

**RESEARCH ARTICLE**

## Development of Brain Computer Interface, using Neural Network

Mr. D. Ravikumar<sup>1</sup>, Dr. V. Devi<sup>2</sup>, Dr. Arun Raaza<sup>3</sup>

<sup>1</sup>Research Scholar, Department of Electronics and Communication Engineering, VISTAS, Chennai.

<sup>2</sup>Dean and HOD, Department of Computer Applications, Gurunanak College, Chennai

<sup>3</sup>Dy. Director Research and Development – CARD, VISTAS, Chennai.

\*Corresponding Author E-mail: [ravi.se@velsuniv.ac.in](mailto:ravi.se@velsuniv.ac.in), [vdevi78@yahoo.com](mailto:vdevi78@yahoo.com), [director.card@velsuniv.ac.in](mailto:director.card@velsuniv.ac.in)

### ABSTRACT:

This paper focus on the development of a Brain Computer Interface (BCI) using neural network, where BCI is an electronic communication system which accomplish the operating principle of “stimulate thinking and make it happen destitute of anyone’s physical efforts”. Based on the environmental conditions the BCI allows the users to act on his thoughts, without using their peripheral muscles and nerves. A machine learning algorithm is included in all the neighboring BCI, which learns a function from the training data’s besides used to distinguish non identical brain activities. The investigation of this work with Brain Computer Interface (BCI) signals possessed from Electro- EncephaloGraphy (EEG) to bring out a relationship between a person’s mind condition and a computer employed signal processing system that illustrates the EEG signals. A Radial basic function framework for machine learning is used here for the linear discriminant analysis of EEG data. Based on the Radial Basic Function’s (RBF) the output an intended mental task can be performed.

**KEYWORDS:** Brain Computer Interface (BCI), Radial basic function (RBF), Electro-EncephaloGraphy (EEG), Neural Networks, Neuron’s, Fast Fourier Transforms (FFT).

### 1. INTRODUCTION:

The Brain Computer Interface (BCI) is a correlation between the human brain and a controlling device that allows the control signals from brain to regulate the external activities, such as prosthetic limb or a control of cursor. This interface allows a direct line of communication over interconnecting the brain and the object to be controlled. A large number of peoples with the condition of being disable to do things in the normal

way using motors, need a technique of reinforcing the idea of original communication. In communication the common augmentative technology cannot be used for many people who observed to be completely paralyzed or “locked in,” all of which requires a remarkable measures in controlling the muscle.

A diversified study has been estimated for the last few decades, about the ability of registering the brain signals within the brain or from the scalp could come through latest augmentative technologies that need not requires muscle control. These BCI systems particularly measures an important attributes of brain activities and transcribes them into device controlled signals.

The attributes used in this case study includes the EEG signal recorded from the front head and a reference signal recorded from the ear lobe is passed through the USB port to interface with the computer and the feature is extracted by using the LAB VIEW software tool box and extracted data is trained by using the Radial Basis Function network to control the particular activity.

### 2. BACKGROUND:

Asim Roy et.al [1] has studied by training the “truncated” RBF and the other type of hidden units, and this algorithm uses random clustering techniques and programming. Following this the Quickness in learning has been recognized, efficiency in learning and Generalization in learning.

Pfustscheller et al [2] have detected two potentials from two electrodes over the sensorimotor cortex (C3 and C4) and also collected signal by intimidating the cursor in the screen and with the help of both signals the net is trained.

Ernst Haselsteiner et al [3] used the Finite Impulse Response multilayer Perceptron to reduce the error rate and in his work Band pass filter is used to separate the frequency range in between 0.5 and 35 Hz to obtain the Alpha and Beta which is the EEG pattern for BCI classification.

H. Z. Tan et al [4] recommended that the user can improve the graphics and visual displays, through haptic feedback and tactile there by allowing the computer to impart more relevant, useful and realistic information.

D. Goldberg et al [5] suggested an enhanced algorithmic technique for the perception of human intention and behaviors, like collaborative filtering.

F. Galán et al [6] proposed the use of neural signals in the way that is more consistent with the spontaneous neural processing for analytic inhabitants are recognized for developing applications by the researchers recently.

A. Nijholt et al [7] conveyed that currently the BCI technologies are extended for the healthy populations by the researchers.

L. A. Washbon et al [8] expressed a statement that now-a-days many applications have an extension of an actual clinical application, still various new types of applications are being developed, inclusive of attempts to blend the emotions into music, advertising, toys and video games.

S. Pradeep Kumar et al [9] suggested a Brain wave sensor to detect the EEG data from the driving person. Drowsy and alert conditions are identified if there is a mismatch between the EEG signal and reference signal, and the alarm will give necessary precaution to the driver.

### 3. EEG SIGNAL CLASSIFICATION:

The Electro-EncephaloGraphy (EEG) signal is significantly a complicated signal, which exhibits the electrical fields developed by a numerous trillions of synaptic individual connections in sub-cortical structures and in the cortex. The EEG signal is extremely corrupted, due to the electrical diagnostic of the cranium and by the complex anatomical science [10]. Almost it is significantly an unstable signal, while the cranium is able to produce the signal from a given motor performance very often with a small amount of apparent variations. The brain activities implicitly vary the output consequently from performance to performance.

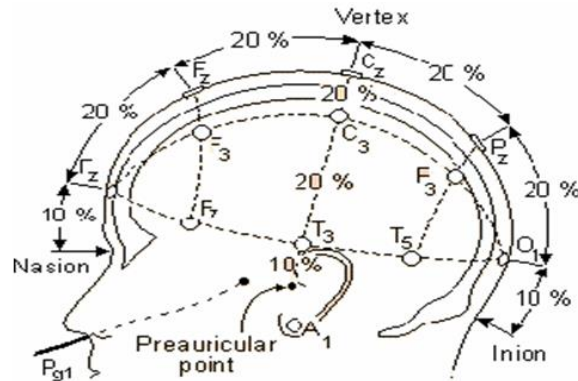

Figure.1 EEG 10 – 20 Lead System, Left side view

In the view of fact, the EEG signals related with the specific outcome also changes from performance to performance. The combining effectuate of these features is the effects to resolve the aim of brain activity from the EEG in a comprehensive style, may be unrealistic. The EEG signals are recorded from the regularly placed electrodes on the top of the head (i.e) scalp and possess an average amplitude of 2 to 100 micro volts and a frequency range of 0.1 to 60 Hz. Almost the brain activity appears within the below frequency ranges; alpha (8 to 13) Hz, beta (13 to 22) Hz, gamma (30 to 40) Hz, delta (0.5 to 4) Hz, and theta (4 to 8) Hz. The particular frequency band is often correlated with particular cognitive states. Spontaneous EEG signals are occur without stimulus. However as a result of occurring the EEG signals for example the mu rhythm signal can be influenced by a specific functional reaction in an organ. By using the operant conditioning or a biofeedback has the ability to enhance and develop a spontaneous intense EEG rhythm such as the mu rhythm and alpha rhythm can be enhanced.

### 4. CLASSIFICATIONS OF RADIAL BASIS FUNCTION:

The Radial Basis Function (RBF) Network architecture is shown in the figure 2. These Radial Basis Function networks comprises of two layers: (i) layer of  $S_1$  neurons which pertain to a hidden radial basis layer, (ii) layer of  $S_2$  neurons referred to a linear output layer. To produce a vector possessing  $S_1$  elements the Radial basis layer explained in the Figure 2 receives the input weight matrix  $IW_1$  and the input vector  $p$ . The distance linking the input vector and vectors  $IW_1$  forms an elements of input weight matrix rows.

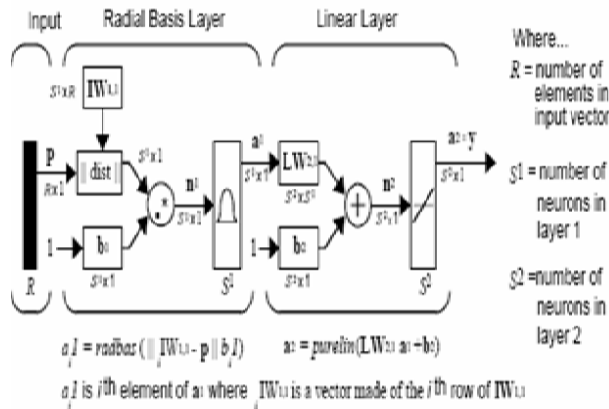

Figure. 2 RBF Network Architecture

By using the MATLAB functions the element by element multiplication can be done by combining the bias vector **b1** and the outputs.

The RBF networks subsequently act in a polite way by an input vector **p** through the network and the output **a2**. When an input vector is given to RBF network, an output value is produced from each neuron in the radial basis layer in proportion to how near the input vector **p** is for every neuron's weight vector. The neurons with weight vectors are exactly dissimilar to an input vector **p** having the output close to zero. This smaller output has an insignificant effect on the linear output neurons. Unlike a radial basis neuron, the input Vector **p** close with a weight vector yields a value close to 1. When an output of a neuron is 1, it passes their values of output weights from the second layer to the linear neurons in the second layer. As a part of the report, if an output of the neurons is 1 for one radial basis function, then all the outputs of the other neurons are close to 0's or 0, hopefully the linear layers output be an active neurons output weights nevertheless would be an extreme cases.

To vary the degrees, various neurons are always firing regularly. Each neurons input weights in the first layer is the distance between the input vectors and its weighted vectors for calculating the dist. The actual input of each neuron is the element by element outcomes of an input weight with its bias, considered as a netprod. The output of each neuron is its net inputs which proceed by means of radbas. When the input vector (transposed) and its 0 weighted input it is equal to neuron's weight vector, where its net input is 0, and the output is 1. From the input vector if a neuron's weight vector is a distance of spread then its weighted input is spread and its net input is square root of(-log(0.5)) (or 0.8436), as a result of this consequence the output is 0.5.

**5. SYSTEM DESCRIPTION:**

The Brain Computer Interface is the simple interfacing system between the user and the computer, where the machine acting as an extension of human nervous

system [11]. This proposed work is to develop the brain computer interfacing system to activate an electrical unit or any movements, and to train the people quickly.

The Block diagram of BCI is shown in Figure 3, it consists of following blocks:

1. EEG Acquisition and Preprocessing
2. Systems.
3. Feature Extraction.
4. Neural Network Training module.
5. Testing system.

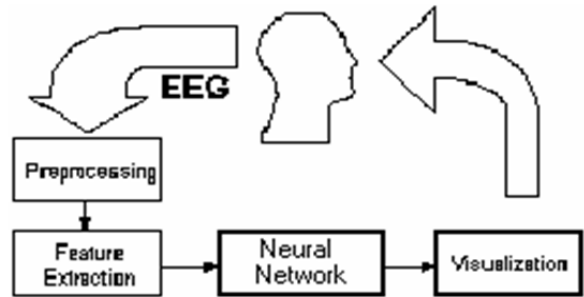

Figure. 3 Block Diagram of BCI

**6. EEG ACQUISITIONS AND PREPROCESSING:**

The EEG signals from F3 region of 10-20 international lead system are picked by using two unipolar gel-filled Ag/AgCl electrodes, while reference is taken from the ear. The picked EEG signal is of very low amplitude signal in the order of 10 – 100micro volts. Such a low level signal is insufficient to directly drive ADC. In order to amplify the signal by 50,000 two stages of amplifier is used. The first stage is instrumentation amplifier with the gain of 5000. For this purpose low power general purpose Instrumentation amplifier (INA 118) is used.

The gain is increased by using the following equation 1

$$G = 1 + \frac{50k\Omega}{Rg} \text{---(equation 1)}$$

In this work, the high precision resistance of 10 ohm is used. So that the gain provided by the instrumentation amplifier is of about 5001.

**6.1 USB DATA ACQUISITION:**

The amplified signal is feed through the USB 6008 port. The basic data acquisition functionalities are provided by using USB 6008 port for the certain applications such as portable measurements, simple data logging and the academic laboratory experiments. Also it is more powerful as much for innovatory measuring applications. From the beginning to evaluate the basic measurements the NI USB 6008 port is ready to run data logger software within a minute.

## 6.2 LABVIEW FOR DATA ACQUISITION AND FEATURE EXTRACTION:

LAB VIEW is more efficient software used for real time data acquisition and signal processing. Here acquired signal is sampled at the rate of 10000 samples per second. In order to eliminate the unwanted signal, filter is used. In this work, the EEG signal with less than 13Hz is needed.

So the Hamming window low pass filter with the cut off frequency of 15Hz was implemented using a LAB VIEW tool box. In this LAB view software MATLAB can be interfaced using a Matlab script file is used to write the code in MATLAB for feature extraction and to train the data using Radial Basis function to activate the particular activity.

## 6.3 FEATURE EXTRACTION:

From the EEG-signals, the feature has to be extracted so that relevant control data only stored. As the number of feature data is less compared to the full data, it reduces the storage capacity and also it reduces the time to train the neural network. In this work, the control task signal is of mu rhythm of EEG data. From the time domain signal, the *mu* band frequency content obtained by FFT analysis and power spectrum analysis. The FFT is obtained by the equation 2

$$X(k+1) = \sum_{n=0}^{N-1} x(n+1) W_n^{kn} \quad (\text{equation 2})$$

Where  $WN = e^{-j2\pi n/N}$  and  $N = \text{length}(x)$ .

## 6.4 TRAINING THE NEURAL NETWORK:

An enhancement in the algorithm is the one more objective in addition which translates the given EEG controls into the device control. On referring this control the features are obtained and feed the input to the neural networks corresponding to the number of samples which are going to be given as the input. The target is estimated and the data will be trained for the particular target and the trained output is obtained.

## 6.5 TESTING:

The trained network is tested with the real time EEG data. If the real time data matches with the trained data the particular activities such as cursor moment in the screen will be achieved as the upward or downward cursor moment

## 7. RESULT:

By using flat disc electrode EEG signal has been acquired and is amplified by using the instrumentation amplifier to increase the gain of the signal to 5000 $\mu$ v. The amplified signal is interfaced to the computer using the USB 6008 interfacing card. The signal having the noise is removed, and the FFT for the signal is also obtained directly using the LabVIEW Tool box. The

feature extracted data is given as the input to network to train. The trained network is tested with the Real time data and the particular activity is achieved.

## 8. FUTURE ENHANCEMENT:

There is lot of development should be achieved in the Brain computer interface. Now it's of developing stage. This work can be extended, such that to attain maximum efficiency in minimum time. In this work, the target activities are arranged in one dimensional fashion. It can be extended to two dimensions as that of matrix, so that the number of activities can be increased.

In this work, only one electrodes and one reference electrode are used for signal acquisition, this can be increased to many number or by sing array fashion of electrodes, so that the output variation is much better for training. This work can be extended by activating more number of senses, so that concentration can be increased. Besides from being a novel technique it can assist a various kinds of applications like playing games, answering queries, driving environment control units and medical diagnosis. Moreover it can also has a extensive commercial applications at places where human intervention is most needed at the same time has health hazard situations.

## 9. REFERENCES:

1. Asim R, Sandeep G, Raymond M.A Neural- Network Learning Theory and a Polynomial Time RBF Algorithm. IEEE Transaction of Neural network. 1997;8(6);1301 - 1313.
2. Pfurtscheller G, Neuper C. Current Trends in Graz Brain Computer Interface (BCI) Research. IEEE Transactions on Rehabilitation Engineering. 2000;8(2); 216 -219.
3. Ernst H, Gert P. Using Time-Dependent Neural Networks for EEG Classification. IEEE Transactions on Rehabilitation Engineering.2000;8(4);457-463.
4. Tan HZ, Srinivasan MA, Eberman B, Cheng B. Human factors for the design of force-reflecting haptic interfaces. Dynamics Systems and Control.1994;55(1);353-359.
5. Goldberg D, Nichols D, Oki BM, Terry D.Using collaborative filtering to weave an information tapestry. Communications of ACM.1992;35(12); 61-70.
6. Galan F, Nuttin M, Lew E, Ferrez PG. Vanacker, Philips J, Millan J. A brain-actuated wheelchair: Asynchronous and non-invasive brain-computer interfaces for continuous control of robots. Clinical Neurophysiology.2008;119(9); 2159-2169.
7. Nijholt A, Tan D, Playing with your brain: Brain-computer interfaces and games. Proc. InternationalACM Conference on Advances in Computer Entertainment Technology. 2007: 305-306.
8. Washbon LA. Electrode headset. U.S. Patent D565, 735, S01 April 2008.
9. Pradeep Kumar S,WiseminLins A. Brain Wave Sensor System for Accident Prevention in Vehicles. ARPN Journal of Engineering and Applied Sciences .2017;12(8); 2455-2462.
10. Christoph G, Alois S, Christa N, Dirk W, Thomas Strein,Gert P. Rapid Prototyping of an EEG-Based Brain-Computer Interface (BCI). IEEE Transactions on Neural systems and Rehabilitation engineering. 2001: 9(1); 49-58.
11. Ulrich H, Gary G, Jean-Marc V, Touradj E. Application of the Evidence Framework to Brain-Computer Interfaces. Proceedings of the 26th Annual International Conference of the IEMBS, USA.2004;1;446-449.DOI:10.1109/IEMBS.2004.1403190