



Sustainable Environment

An international journal of environmental health and sustainability

ISSN: (Print) (Online) Journal homepage: <https://www.tandfonline.com/loi/oaes21>

Impacts of residential energy storage system modeling on power system

Sushita K, Shanmugasundaram N, Kannadhasan Suriyan, Nagarajan R & Kanagaraj Venusamy |

To cite this article: Sushita K, Shanmugasundaram N, Kannadhasan Suriyan, Nagarajan R & Kanagaraj Venusamy | (2022) Impacts of residential energy storage system modeling on power system, Sustainable Environment, 8:1, 2125905, DOI: [10.1080/27658511.2022.2125905](https://doi.org/10.1080/27658511.2022.2125905)

To link to this article: <https://doi.org/10.1080/27658511.2022.2125905>



© 2022 The Author(s). This open access article is distributed under a Creative Commons Attribution (CC-BY) 4.0 license.



Published online: 27 Sep 2022.



Submit your article to this journal [↗](#)



Article views: 1331



View related articles [↗](#)

Impacts of residential energy storage system modeling on power system

Sushita K^a, Shanmugasundaram N^b, Kannadhasan Suriyan^c, Nagarajan R^{id} and Kanagaraj Venusamy^{id}^e

^aResearch Scholar, Department of Electrical and Electronics Engineering, Vels Institute of Science, Technology and Advanced Studies, Chennai, India; ^bDepartment of Electrical and Electronics Engineering, Vels Institute of Science, Technology and Advanced Studies, Chennai, India; ^cDepartment of Electronics and Communication Engineering, Study World College of Engineering, Coimbatore, India; ^dDepartment of Electrical and Electronics Engineering, Gnanamani College of Technology, India; ^eDepartment of Mechatronics, Rajalakshmi Engineering College, Thandalam, Chennai, India

ABSTRACT

Power system reliability can be improved with the use of energy storage. Energy storage technologies are examined critically, including storage kinds, categorizations, and comparisons. Electrochemical and battery energy storage, thermal and thermochemical energy storage, flywheel energy storage, compressed air energy storage, pumped energy storage, magnetic energy storage, chemical and hydrogen energy storage are all taken into account. The recent research on novel energy storage kinds and its significant achievements and discoveries in energy storage are analyzed. It is the goal of this study to undertake a complete and systematic evaluation of the influence of battery energy storage systems (BESS) on power systems and microgrids. Peer-reviewed studies published between 2010 and the start of 2021 provides the basis of the SLR (Systematic Literature Review). Due to inadequate wind or sunlight, renewable energy sources (RESs) like wind and solar are regularly subjected to swings. Energy storage technologies (ESTs) help to solve the issue by storing extra energy and making it available when it's needed. Despite the fact that there are several EST investigations, the literature is fragmented and out of date. The comparison of EST features and applications is very brief. The purpose of this article is to fill that void. It identifies major ESTs and offers an updated overview of the literature on ESTs and their potential use in the renewable energy industry, based on a set of criteria. The critical analysis reveals that Li-ion batteries have a high potential applicability in the utility grid integration sector and are BESS suited to alleviate RES volatility. However, Li-ion batteries' costs must be decreased in order for them to be completely utilized in RES utility grid integration. It has long been shown to improve system dependability and reduce transmission costs by introducing energy storage into power networks. The development of energy storage devices is aided by regulations that promote the use of renewable energy sources rather than fossil fuels. There are also voids in this field of research. To help academics better grasp the dependability implications of energy storage systems and fill in knowledge gaps in the field, this review is available. Reduced emissions and global warming as a result of the increased usage of renewable energy resources in terms of renewable energy, wind turbines and solar PV systems are two of the most common. In contrast, the advantages and downsides of using renewable energy sources are numerous. Renewable energy's biggest flaw is its inability to generate consistent amounts of power. It is difficult to maintain a balance between generation and demand due to the irregularity of renewable energy sources' power output and the sudden spikes or dips in demand. Consequently, there will be deviations in grid voltage and frequency, leading to operational difficulties and perhaps jeopardizing grid stability. Battery energy storage systems (BESS) can be used to regulate the output of renewable energy sources and keep the grid stable.

ARTICLE HISTORY

Received 06 April 2022
Accepted 11 September 2022

KEYWORDS

BESS; ESS; smart grid; power system; AC and DC

Introduction

The primary objective is to thoroughly and methodically examine the reliability implications of energy storage technologies in this sector. Peer-reviewed studies from 1996 to the start of 2018 provide the basis of the Systematic Literature review (SLR). Research reveals that adding energy storage into power networks is crucial for enhancing system reliability and reducing

transmission upgrading costs. Energy storage system development is also influenced by policies that encourage the use of renewable energy rather than fossil fuels and implications of energy storage systems and identifying knowledge gaps.

Through this study, the most efficient storage technologies may be employed in a power system. The decision support tool uses a co-optimized power market

CONTACT K Sushita  sushita.se@velsuniv.ac.in  Research Scholar, Department of Electrical and Electronics Engineering, Vels Institute of Science, Technology and Advanced Studies, Chennai, Tamilnadu, India

Reviewing editor: Siming You School of Engineering, University of Glasgow, United Kingdom

© 2022 The Author(s). This open access article is distributed under a Creative Commons Attribution (CC-BY) 4.0 license.

You are free to: Share — copy and redistribute the material in any medium or format. Adapt — remix, transform, and build upon the material for any purpose, even commercially. The licensor cannot revoke these freedoms as long as you follow the license terms. **Under the following terms:** Attribution — You must give appropriate credit, provide a link to the license, and indicate if changes were made. You may do so in any reasonable manner, but not in any way that suggests the licensor endorses you or your use. **No additional restrictions** You may not apply legal terms or technological measures that legally restrict others from doing anything the license permits.

and accounts for arbitrage advantages to respond quantitatively “where to install and how much to install”. The framework is shown using the Reliability Test System RTS 24 bus RTS, which determines the BESS available allocation choice for each site as well as the net profit of each site. When compared to transmission extension methods, CAES [Compressed Air Energy Storage] is the most widely deployed storage technology in the grid. Because they create toxic byproducts, these fossil fuels are not ecologically friendly.

Using the t-test analytic technique, this study will show whether or not a battery can genuinely assist the performance of the microgrid system, how much it contributes, and what kinds of situations the BESS is most advantageous in. It shows that there is a big difference between systems that use batteries and those that don't. Using a BESS to improve system reliability while utilizing energy arbitrage was the focus of this study. In the course of carrying out energy arbitrage, the goal of maximizing profits from the market for energy has been emphasized. The BESS state of charge was used to build a multi-state model. As a result, the BESS states have been categorized as both generators and loads when it comes to assessing generation adequacy in the United States. The suggested model was tested using the IEEE Reliability Test System. The results reveal that the system's reliability is significantly enhanced by the BESS's existence (Cie'slik, 2014; Sanduleac et al., 2019; Tang et al., 2019; Vai et al., 2020; Y. Zhang et al., 2016).

This research presents an optimization strategy for the BESS placement of the BESS in an unbalanced distributed system based on the loss sensitivity index. When selecting where to put the BESS, the sensitivity index for each system bus is taken into account. Use the phase-wise sensitivity index rather than the total sensitivity to find the BESS location for the BESS. BESS can be arranged in priority order, starting with the bus with the highest negative sensitivity and working down to bus with the lowest negative sensitivity, using this method. It is shown that the BESS can be optimized for various operating situations by discovering the BESS amount of power to be given or absorbed. An IEEE test bus system was used to test out the new method proposed. To reduce total system losses, BESS and a wind generator were used, along with improved voltage profiles for the separate bus systems.

Other renewable energy sources, such as wind and solar power, might be investigated in the future. Modeling on alternative energy sources is restricted, to the BESS of the authors' knowledge. Future study might focus on developing accurate and efficient models to further evaluate the credibility of various sources.

There might also be research on the dependability of hybrid energy storage in today's power systems. Hybrid energy storage is evolving at a high rate in terms of technical improvement. The issue is that it isn't yet attractive enough to be used in real-world settings. Scientists may investigate its influence on power system dependability in order to help utilities make better decisions in the future.

A microgrid is a contemporary distributed power system that uses local renewable energy sources and was created using smart-grid technologies. It also offers tiny towns with energy security due to its capacity to operate without the need of a larger utility grid. Microgrid technology is often related with physical and cyber reliability, environmental sustainability, and economics (cost optimizing, efficiency). Power generating that is located near to where it will be consumed is referred to as “distributed generation” (DG). By minimizing elements of complexity and interdependency, DG may decrease the costs of generation, transmission, and distribution. Distributed generators have the potential to cut production costs and enhance dependability due to their smaller size, reliability, and security. According to Pike Research, the world's microgrid capacity is at 3.2 gigawatts (GW) [2017]. North America is the global leader in microgrid generating, with a total operating capacity of 2,088 MW [2017]. Europe, on the other hand, has 384 MW of microgrid capacity built, while Asia Pacific has 303 MW of operating microgrid capacity. Europe is ranked second. Microgrids have an installed capacity of around 404 MW across the remainder of the globe [2017]. The most costly power system would be made up of all users (buildings, companies/hospitals/markets) that are concerned about stable electricity and need a backup energy source (generation/battery/diesel engine). Because no one user is needed to provide the whole demand at peak periods, microgrid systems do not require the deployment of backup supplies. By changing or lowering loads for a few hundred summer peak hours, one billion dollars in yearly energy expenses might be saved. As a consequence, a microgrid's dependability is a major selling factor. Microgrids might become economically viable in the southern United States in the near future. It's critical to examine the long-term viability of this new technology before evaluating it. In the United States, the relevance of this issue is less urgent, but it is vital in China, where many new environmental concerns are arising. Because transmission losses are considerably minimized, the microgrid may be able to address the energy issue.

A microgrid also reduces the cost of power generation while maintaining long-term consumer supply. Because of the system's localized character, the cyber security problem is also handled. Because rural regions

lack enough transmission infrastructure, an island microgrid would be the most cost-effective way to use microgrid technology. As researchers explore microgrids in depth in order to build test beds and demonstration locations, it is critical that the taxonomy of microgrids and the necessary core technologies be addressed. The three types of microgrids discussed in this paper are facility microgrids, remote microgrids, and utility microgrids. It's crucial to consider their varying degrees of utility grid integration, their influence on major utility providers, as well as their distinct responsibilities and application areas. Utility connections are available in facilities and utility microgrids, but not in remote microgrids. Remote microgrids are situated in more scattered locations, whilst facility and utility microgrids are located in more concentrated consumption areas. Facility microgrids may continue to run in an island state, whether by purpose or by accident. Variables such as micro sources, micro loads, network features, and control topologies will vary depending on the kind of microgrid.

Because of its high dependability, high quality power supply, environmental preservation, and energy cost reduction, photovoltaic (PV), wind turbine (WT), combined cooling, heating, and power (CCHP), and fuel cells have gotten a lot of attention. Increasing the number of distributed generators, on the other hand, will create as many issues as it solves. It will be challenging to manage and regulate a big number of dispersed generators. If distributed generation is handled as a system rather than a collection of discrete components, it may be accomplished more efficiently. The power system's incompatibility with scattered generation may be addressed while the system's overall performance is improved using microgrid technology. Microgrids may operate in grid-connected or islanded modes since they can be unplugged from the grid in the event of a network breakdown. The most efficient type of distributed generation is the microgrid.

Microgrid technology is now generating a lot of buzz. The CERTS [Consortium for Electric Reliability Technology Solutions] microgrid test bed, GE [General Electric] microgrid, Aichi, Kyoto, and Sendai microgrids in Japan, and Labein Kythnos and CESI microgrids in Europe have all been developed as part of the development of sophisticated distributed generation systems. Furthermore, since the microgrid is a novel concept, further study is required to properly comprehend its practical applications. Microgrid performance is heavily influenced by design and control difficulties. It's critical to find out how to build a sensible and effective microgrid system configuration and control system. MMS [Manufacturing Message Specification] and a local controller [LC] are the two tiers of control. The MMS, a centrally managed system, handles management activities such as microgrid disconnections and resynchronizations, as well as load shedding. The MMS is also in charge of ESS and microsource supervisory control. Based on data acquired locally, the MMS sends a power output set point to the LCs. The basic purpose of an LC is to control power output in line with the MMS set point.

The microgrid's control performance is aided by the hierarchical control structure. In addition to the physical control system, microgrid research focuses on strategies for regulating power flow. Microgrid control has become increasingly complicated and difficult due to the instabilities of distributed generation and the unpredictability of distributed generating units. There are substantial variations between generators linked to the grid directly and those connected to a microgrid's busbar through power electronic equipment. The inclusion of qualities like these may help increase the inertia of an energy storage device. In controlling microgrid operations, standard control approaches no longer operate, as shown in Figure 1 (Miranda et al., 2016).

At current moment, peer-to-peer and master-slave control are the most popular control systems. To

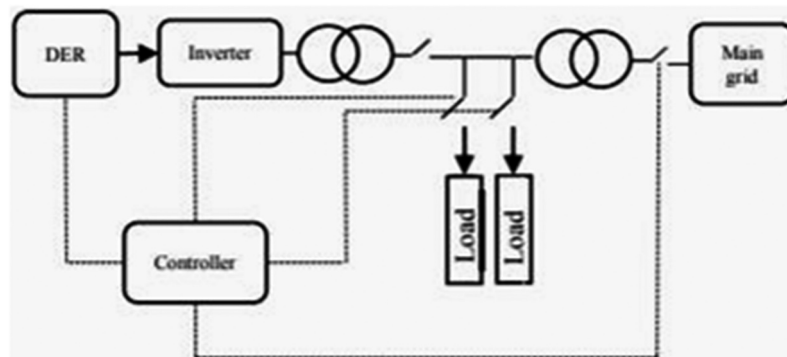

Figure 1. Microgrid technology [12].

maintain the voltage and frequency consistent, a primary control unit in master-slave control is used. V/F control is used by the central control unit to create exact active and reactive power, whereas PQ control is used by the distributed generators. In a peer-to-peer network, each node may be operated individually. Peer-to-peer control uses an approach based on external degradation indicators. This gadget connects the frequencies, voltages, and reactive power. The voltage and frequency may be changed automatically without the need for communication using a customized algorithm.

In peer-to-peer control, the drooping characteristics-based control technique is widely utilized. Distributed generation systems, for instance, can be controlled with f-P and V-Q control, which generates reference active and reactive power from idle distributed generation systems by measuring the system frequency and amplitude of output voltage from idle distributed generation systems and generation facilities. If solar power was much less than the transfer capacity of existing facilities, it may be expanded. To further comprehend this problem, imagine a large PV farm with a gigawatt output similar to a nuclear power plant. Due to the low yield per square meter of PV production, generating such a large quantity of power requires a large area of land. As a consequence, power plants must be placed far away from the areas where they will be utilised. The transmission infrastructure must be capable of handling the maximum current that can be produced under ideal circumstances.

Artificial intelligence (AI) is a key component of the carbon-neutral society that has attracted a lot of interest from energy supply companies, startups, technology developers, financial institutions, national governments, and the academic community. Examples include self-driving cars, voice recognition-based virtual digital assistants, smart thermostats, and recommendation systems. The emergence of AI opens up a wide range of opportunities for the energy sector to transform into an AI-powered smart system that can revolutionise established methods of creative problem-solving, strategic operation, and operation. This is especially true for hastening our society's transition to a carbon-neutral future. In the Energy Internet (EI), applications of big data analysis support smart energy supply and consumption, smart health, and fintech. This study offers a thorough understanding of these foundational concepts. Then, by carefully examining the literature and concentrate on making wise decisions for the energy sector and update the state-of-the-art. Following that, new developments in cybersecurity for AI systems connected to EI are reviewed, including vulnerability analysis of AI systems, differential

privacy, and blockchain-based security technologies. This is one of the first academic, peer-reviewed publications that, to our knowledge, provide a thorough evaluation of AI applications for EI research and efforts in terms of large data analysis, intelligent decision-making, and AI related cybersecurity. These projects were carefully divided into several categories based on their application, technique, and contribution. Then, possible difficulties, restrictions on current research, and prospects for future approaches are reviewed for a variety of topics, including explainable AI, localised multi-energy markets, self-driving electric car charging, and e-mobility. This study may aid in our understanding of how to create climate-smart cities and essential infrastructure in order to achieve the UN's sustainable development objectives (Chaojie, 2021).

Renewable energy sources and electrified transportation systems are acknowledged as effective environmentally friendly technology against greenhouse gas-induced global warming (GHG). Surprisingly, electric cars fuelled by hydrogen fuel cells may beat battery-powered vehicles primarily in terms of driving range and refilling time. To significantly reduce GHG emissions, both of them need stronger infrastructure system and renewable energy resource cooperation. In order to achieve maximum traffic flow coverage, the capacitated flow refuelling site model is used in this article's planning model for hydrogen refuelling stations. To make the planning model more useful and also explore several real-world restrictions, such as energy limits for electric cars, hydrogen balance constraints, distribution network constraints, and traffic network constraints. A method for spatially spreading hydrogen across the stations is also described, taking into account the unpredictability of the short-term refuelling demand throughout the city. The least cost of redistribution is approximated by the travelling salesman issue for one commodity pickup and delivery. In order to demonstrate the effectiveness of the planning model at both present and future cost levels, a real-world case study of Western Sydney is used. Finally, the viability of the hydrogen redistribution mechanism is shown using a numerical simulation (J. Zhang et al., 2022).

The deployment of energy storage systems (ESSs) is a major way to increase a distribution network's energy efficiency, and their ideal positioning, size, and use may improve overall network performance. An ESS that is properly scaled and positioned may enable meeting peak energy demand, increase the advantages of integrating renewable and distributed energy sources, help regulate power quality, and lower the costs associated with expanding a distribution network. The location, size, and use of an ESS are discussed in this work.

The merits and disadvantages of the suggested systems and methodologies are discussed, along with a variety of grid situations, targeted performance targets, applicable tactics, and ESS kinds. Although batteries are often utilised as ESSs in a variety of applications, a thorough comparison of ESS technical attributes indicates that flywheel energy storage (FES) should also be taken into account in certain distribution network situations. This study offers suggestions for pertinent specifications or practises, suitable ESS selection, intelligent ESS charging and discharging, ESS size, location and operation, and power quality concerns. This study also indicates areas for future research in regard to concerns with development and implementation, optimisation approaches, societal consequences, and energy security, as well as obstacles for the best ESS placement planning.

With increased duty to ensure a dependable, consistent, and high-quality supply of electricity at the transmission and distribution levels, today's power system network is increasingly complicated. In the event of an unanticipated generation shortfall, a system disruption, or the inclusion of intermittent renewable energy sources like wind and solar power in the energy mix, maintaining grid balance becomes a more pressing concern. An energy storage system (ESS) may be thought of as a crucial option in order to correct such imbalance and enhance the dependability and stability of the power system. Additionally, when integrating renewable energy sources into the power system network, ESS may be utilised to reduce any related problems. As a result, ESS encourages efficient grid integration of additional renewable energy sources to achieve a decrease in greenhouse gas (GHG) emissions. Energy Storage (ES) technologies come in a variety of forms and are employed in the network of power systems at scales ranging from big (MW) to tiny (KW). Each storage technology has a certain application function that it is fit for depending on its kind and qualities. This article gives a thorough overview research on different ES technology kinds from the standpoint of features and applications. In-depth examples of several ESS applications are also provided. Finally, a feasibility study has been conducted using the ES-selects uTM/su tool software to find a viable ES technology for applicable applications at various grid sites and also assists in the development of a smart hybrid storage system for grid applications in the future.

Recently, focus has increased for distributed generation (DG). This is mostly because of the many benefits of DGs, including their capacity to reduce electrical energy loss in the distribution system, voltage

fluctuations, increase dependability, enhance power quality, lower energy costs, and ultimately increase customer happiness. Despite all the advantages of DG for power systems, integrating these new technologies to the national energy systems creates some serious issues including modifying the protection setting, unstable power systems, and islanding phenomena.

Renewable resources, including wind and solar power plants, or nonrenewable resources may be used to generate electricity using DGs (conventional methods). The key issues are output power changeability and uncontrollability, which arise when using the majority of renewable energy sources as DGs, such as wind farms and photovoltaic (PV) systems. In fact, when using DGs in a power system, these key characteristics raise more concerns. One of the best options in this regard is to use an energy storage system (ESS), which is what is being suggested. Engineers may control the power system properly with the help of this new category.

Energy storage system

The environmental advantages of integrating renewable-based distributed generation (DG) into distribution networks have recently gained a great deal of attention across the world. However, the intermittent and variable nature of renewable energy sources, such as solar and wind, has an impact on the distribution network's performance and dependability. Surplus power generation at one point and it is used in deficiency of electricity generation elsewhere. A rise in voltage in the distribution network due to higher DG penetration may also cause difficulties in the network due to significant reverse power. Numerous studies have been conducted on the technology and uses of the energy storage system (ESS), as well as the appropriate placement and scale. According to a study of the various electrical energy storage systems in terms of their technical properties and their use, an appropriate control plan is essential for the proper use of long-term storage technologies. The in-depth analysis of the real-world situation discusses the use and effectiveness of various ESS. According to the study's findings, batteries accounted for the bulk of operating projects, followed by pumped hydro energy storage. According to a study on battery storage system size, the criteria and methods for determining the suitable storage capacity are heavily dependent on the application and power network capability.

Energy storage systems (ESS) have been advocated as a way to improve the stability and dependability of renewable energy generation. Smoothing output from renewable generators, providing ride-through capability when a generator goes down, and storing electricity

during low demand periods and supplying power when there is high need are all examples of how ESS may help the distribution network. Increased costs from oversizing ESS, on the other hand, might limit its economic application in distribution networks. If the ideal quantity and placement of ESS aren't found, utilities would be further burdened by the high initial investment costs of ESS installation. When it comes to the arrangement and size of objects, there is no single answer.

Meeting GHG [Green House Gases] emission reduction objectives would need a multi-pronged strategy to decarbonizing all GHG-producing sectors, including intersectional measures. Energy storage systems (ESSs) have emerged as a leader in tackling some of the issues associated with the transition to renewable-based power delivery. Provide a systems-level evaluation of more than 100 relevant publications in order to highlight significant lessons on the significance of ESSs and research needs. Most decarbonization studies looking into the role of ESSs do not take into account ambitious emissions targets like the IPCC's goal of keeping global warming below 1.5 degrees Celsius

- (i) The role of ESSs in low-carbon electricity pathways is heavily reliant on local contexts (such as decarbonization policy etc.)
- (ii) From a technology standpoint, duration and capital cost are the most important factors in determining the viability of each ESS technology; short-duration storage (e.g. batteries) plays a dominant role in solar energy integration and partially replacing peaker plants, while mid-duration storage (e.g. flow batteries, PHES) helps reduce variable renewable energy (VRE) curtailments, and long-duration storage (e.g. CAES, P2G, hydrogen) helps
- (iii) Virtual ESS solutions can provide similar flexibility without requiring a large upfront investment in hardware, rather through improved optimization, control, and measurement algorithms
- (iv) Planning models that do not account for the technical characteristics of ESS technologies are insufficient for evaluating technology tradeoffs.

Due to a wide range of system needs and energy storage technologies, this research will look at principles for properly putting an energy storage system (ESS) in various distribution networks. While all of this is happening on, it's critical to remember the BESS practices for operating an ESS distribution network, particularly when it comes to DG integration. If the equipment is used in an unplanned or uncontrolled way, the ESS and

DG operator may incur significant losses. It is hard to predict the operational condition of any generating plant in advance when the optimum operating strategy between the ESS and the grid has not been defined by a specific plant, particularly when the ESS and the grid are not integrated optimally. It's also not often considered that ESS (specifically, Battery Energy Storage System (BESS)) must be charged and discharged several times. Unsuitable SOC [State of Charge] upper and lower limits, as well as repeated charge/discharge cycles, may significantly reduce the lifetime of BESS. Many control methods for ESS operations have already been created, and this paper examines the present situation in full (Bahramirad et al., 2012; Fortenbacher et al., 2016; Makarov et al., 2012; Miranda et al., 2016; Zhao et al., 2015).

To accommodate fluctuating electrical demand, current power systems continue to rely heavily on dispatchable fossil fuels. Electrical energy storage (EES) technologies are increasingly needed to address the supply-demand balance challenge over a wide range of timescales as fossil fuel generation is gradually replaced with intermittent and less predictable renewable energy generation in order to decarbonize the power system. However, existing EES technology deployment in power systems is much below the predicted capacity necessary for power decarbonization. By examining and debating the techno-economic prerequisites for EES, this study provides a complete analysis of EES technologies and analyses ways to expedite EES adoption in power systems. Individual EES technologies and power system applications are defined, providing direction for evaluating individual EES technologies for specific power system services. Following that, talks on storage cost modelling and estimates for various EES technologies are discussed, as well as the realistically necessary sizes and technology kinds of EES throughout various areas. The benefits and drawbacks of creating scalable, economically feasible, and environmentally friendly EES technology are highlighted. The study examines EES's changing responsibilities and problems in power system decarbonization, as well as providing important information and suggestions on EES for future research and development, storage market development, and policy-making in the transition to zero-carbon power systems.

A SMES [Superconducting Magnetic Energy Storage] system has a storage capacity of up to 10 MW. A huge superconducting coil that has been cryogenically cooled to a temperature lower than its critical superconducting temperature creates the magnetic field, which is used to store energy. Two of the most important components of SMES are solenoid or toroid superconducting coils. When it comes to controlling electrical power, the

solenoid is the easier to utilize of the two coil types. Reduced stray fields are required for SMES applications, which may be done by utilizing a toroid. To charge and discharge the coil, power conditioning systems (PCS) are used. The voltage source converter and the current source converter are both widely used. Despite the SMES's high efficiency and short response time, its superconducting wire is quite expensive. Currently, the SMES is not commonly used in the distribution network. The distribution network is projected to play a crucial role in guaranteeing power system stability and quality as more renewable energy sources are employed in it.

FES saves energy for power systems when the flywheel is attached to electrical equipment. The flywheel will obtain electricity from the power system while it is operating as a generator or a motor, and vice versa. The usage of a power converter with an electric machine is typical practice in order to increase the equipment's working range. FES, on the other hand, has a lower total cost of ownership, a longer usable life, is more efficient, and is not limited by discharge depth. External pressures, on the other hand, make idle losses the key concern for a viable flywheel design. The FES's rapid response frequency control is ideal for short and medium-term applications. Between charged plates, capacitors store energy. The energy storage capacity may be increased by raising the capacitor's capacitance or the voltage across the plates. The storage capacity of these dual-layer capacitors has been increased thanks to the increased surface area of a porous electrolyte in supercapacitors, also known as ultra capacitors. Supercapacitors have a higher energy density due to their huge size (up to a hundred times that of a typical electrolytic capacitor). Supercapacitors offer various advantages, including the ability to charge and discharge on a regular basis without degrading, high efficiency, and a longer lifetime. Because of their high daily self-discharge rate and high initial cost, supercapacitors are only recommended for small-scale, short-term storage. Supercapacitors are often used in distribution networks for energy smoothing and momentary-load devices, which provide the power system during voltage sags and transient interruptions, and are also ideal in certain instances when high peak-power and low energy are needed. When discharging, chemical energy may be converted to electrical energy, and when charging, the process is reversed.

Batteries control and a personal computer system (PCS) are round out the BESS. Cells are connected in series and parallel to provide the needed voltage in batteries. These include lead-acid, sodium sulphur (NaS), lithium ion, metal air, and flow batteries.

Regenerative fuel cell (RFC), vanadium redox (VR) and zinc bromine flow batteries can also be sub classified (ZnBr). Lead-acid batteries are the oldest and most established BESS, having been used in the vast majority of power systems worldwide. Bulk energy storage, quick charging and discharging, and a lower price point make the lead-acid battery an attractive alternative for several applications. To make up for these shortcomings, lead-acid battery technology has a limited lifespan.

Because of their high power densities, Li-ion and NaS BESS technologies have a lot of attention. Pure sodium explodes instantly when exposed to air, hence Li-ion batteries are more expensive than NaS batteries since they need specific circuits to protect the battery. Flow batteries have the advantage of long-term storage due to their inability to self-discharge. These devices have high power, short response times, and need less maintenance. For small-scale energy storage applications, flow batteries, on the other hand, are prohibitively costly. BESS may be tremendously profitable in the distribution network for applications like as power system management, power system protection, spinning reserve, and power factor correction, to name a few. BESS technologies including as lead acid, lithium-ion, and sodium sulphide (NaS) are often used in distribution networks (Arefifar et al., 2012, 2013; Bhuiyan & Yazdani, 2010; Hu et al., 2009; Yi et al., 2011).

Because just three types of PV installation patterns were evaluated, this study is not useful for systems with a bigger network because the ideal location was chosen from the combination that yielded the BESS results (lowest reduced power flow). In, theoretical study of the bottom and upper limits of the battery size was used to calculate the capacity of BESS attached to grid-connected PV systems. After assessing the performance of all feasible BESS capacities, Cref within the lower and upper bounds, an approach was presented to achieve the critical BESS capacity. The cost function $J(C_{ref})$ could not be evaluated for all Cref since Cref was a continuous value. To ensure that the optimal capacity computation is as accurate as possible, just a small number of Cref were used to approximate the function $J(C_{ref})$. It has been proposed by Liu et al. that it is possible to improve wind penetration without compromising grid frequency deviation. In order to perform a time-frequency translation, the suggested technique computed the wind fluctuation's power spectrum density using theoretical analysis rather than dynamic simulation. Before starting the power system simulation, complicated mathematical formulae were needed to convert the grid frequency deviation from time domain to frequency domain and then recover to time domain again. In a power system with fluctuating resources, Makarov et al. established

the maximum ESS size by categorizing various cycling components of the balancing power. It was essential to separate the required balancing power into multiple time-varying periodic components using the Discrete Fourier Transform (DFT). The sensitivity analysis done by Mercier et al. used a BESS sizing method.

In order to increase profitability, the optimization procedure took flexible state of charge limits and energy arbitrage into account while determining the ideal BESS rated power value. Because the dynamic simulation was based on the time domain rather than difficult mathematical equation derivations, the computational cost was lower. Provided an enhanced impedance matrix analysis in which the BESS allocation of BESS may be discovered simply by computing the minimal current injection for each node. The Jacobian analytical gradient of the objective function and constraints was used to improve optimization performance, especially when the optimization problem's dimensions grew larger and more complicated, as proposed. Bi-objective optimization was used in to minimize the overall investment and operating costs, along with the loss of load expectation. The Pareto solutions were first obtained using the ϵ -constraint approach, and then the BESS acceptable solution was selected using the fuzzy methodology. In this study, a probability distribution function was used to generate 500 load scenarios for the case studies. Due to the computing complexity, the possibilities were whittled down to only five, and the scenario reduction method assigned probabilities to each one. To top it all off, getting to the Pareto solutions didn't ensure that the greatest possible combination of answers would be found. In, a two-stage microgrid planning strategy was presented in order to reduce the costs of the grid, DG, BESS, and controlled loads. Prior to determining the ideal operating methods, the optimal allocation was calculated without taking operational uncertainty into account. Hot water systems and interruptible loads as controlled loads were highlighted in this paper, which included thorough mathematical models.

Renewable energy sources

In the past, energy storage systems (ESS) have been used to stabilize and compensate for local power instability in power systems. Renewable energy sources like wind farms necessitate reactive power assistance, which is required by industry standards for system safety and operation. In order to avoid security issues and voltage instability, these standards stipulate that WT [Wind Turbine] must meet certain performance requirements, including the need that they contribute to the generation of adequate reactive power in addition to active

power. These standard criteria can be met with the help of strategically sized and positioned BESS. According to research, there are a variety of ways to improve performance. Physical battery model and voltage regulation and peak load-shaving orientated energy management system proposed in by a cost benefit analysis-based goal function for the sizing of energy storage systems in distribution networks with high penetration of Photovoltaic (PV) and ESS. According to the charts in this research, as the penetration of PV grows, so does the requirement for additional ESS. A stochastic cost-benefit analysis model based on wind speed data is proposed in and used for ESS sizing. There is no justification for the deployment of energy storage systems (ESS) in the power grid due to the high cost of ESS installation and low charging and discharging efficiency. Heuristic procedures based on voltage sensitivity analysis and a multi-period optimal power flow framework were used to formulate the sizing problem in, for which semidefinite programming was used to solve the problem with the objective of average network loss, number of ESS and total installed capacity. In grid-connected PV systems, the goal is to reduce net power purchase costs from the electric grid and battery capacity loss while meeting the load and lowering peak electricity purchase from the grid, as described in articles like. According to an ideal ESS size can maximize wind penetration without compromising grid frequency deviation (Atwa & El-Saadany, 2010; Atwa et al., 2011; Chowdhury & Koval, 2004; Wacker & Billinton, 1989; Wang et al., 2009).

In order to perform a time-frequency translation, the suggested technique computed the wind fluctuation's power spectrum density using theoretical analysis rather than dynamic simulation. With the consideration of ESS's charging and discharging cycles, proposed a method based on long-term wind power time series (WPTS) and the computation of mean wind power. The greatest amount of energy that can be stored in various methods of energy storage may be calculated using any one of these components. This need is the theoretical upper limit of what a power system can handle physically. Cost-benefit analysis may be used to determine the real energy storage capacity within this range. as a basis for future endeavors When it comes to allocating energy storage systems, several studies have suggested utilizing the non-linear AC optimum power flow to be turned into a linear programming issue and then addressed using forward backward sweep optimal power flow. In several works, MILP (mixed integer linear programming) was used to size and position ESS. ESS capacity in a micro-grid (MG) was calculated by minimizing overall MG costs, which included both ESS investment costs as well as MG running costs. An MILP algorithm

was utilized for the ESS sizing, while a Monte Carlo simulation was employed to account for random uncertainties and to calculate the MG reliability.

Artificial intelligence (AI) does not need sophisticated mathematical models and algorithms to find the BESS ESS allocation, unlike the analytical and numerical methodologies outlined above. Instead, the AI method is to seek for the BESS answer in the problem space. This technique does not guarantee an ideal answer, but the AI algorithm's capacity to find a solution is often sufficient. The goal of this project was to reduce the cost of the rated power and energy capacity. New heuristic algorithm termed Harmony Search (HS) imitates the improvisation of musicians. In, a genetic algorithm for reducing net present value linked to power losses is used to determine the ideal location for battery energy storage, as well as the BESS operation at varying percentages of load levels with specified electricity prices for each level. The energy storage system's cost-benefit ratio is optimized in relation to energy loss costs, and the arbitrage advantages of this installation were not taken into account. By implementing BESS at allowed nodes of a distribution system, a genetic algorithm-based bi-level optimization strategy decreases voltage variations induced by PV penetration. Using a GA to find the solution space and a sequential quadratic programming (SQP) inner algorithm to solve the objective function, presented the ideal sizing and location of BESS in order to reduce the overall network maintenance costs. At stage one of optimization, a GA was used to find and update the ideal allocation parameters, and at stage two, an AC optimal power flow assessed the fitness function with the optimized allocation parameters. There was an objective function weight assigned to each of the cumulative voltage deviations from the reference voltage and the overall power losses. Capacitors can be installed on the buses that have the highest influence on actual power losses when compared to the nodal reactive power, according to a sensitivity analysis. GA was used to choose the optimal combination of capacitor count and tap position, hence reducing installation costs and real power losses to a minimum. To make the solution more practical, the equations for expressing the storage lifetime more precisely were derived in this study. ESS allocation was also optimized using particle swarm optimization (PSO). Power losses in the distribution network can be reduced by using a fuzzy PSO to solve the ESS allocation problem. According to it is possible to reduce the overall system cost and voltage deviation by using a hybrid, multi-objective particle swarm optimization (HMOPSO) approach that incorporates elitist non-dominated sorting GA and PSO. Using a modified PSO, a strategy was proposed in for

allocating the ESS and DG in a radial distribution system that was modeled as a nonlinear optimization problem. Aside from active and reactive power, this effort looked at the optimization of both ESS and DG, not only ESS. Objective function for reducing distribution system losses in different seasons is developed, however load flow equations and BESS power limit were not included in optimization problem and only active losses are addressed. The aim function in is to reduce the BESS's hourly social cost. Actual data and a curve fitting method are used to estimate the stochastic generation and load of wind energy. Probabilistic optimum power flow is used as a cost-cutting strategy (POPF). Reactive power scaling and PQ performance limitations are absent from this investigation. But load flow equations and reactive power demand are not incorporated in the design of the optimization problem.

- (i) The voltage support for storage systems to the grid
- (ii) Network losses
- (iii) Cost of energy flow to external grid are all taken into consideration

Heuristic approaches are necessary since the issue is non-convex, non-linear, and mixed integer. Constraints on power flow are incorporated, although power limits and the BESS budget are not. Multiple BESS and WTs are integrated in this study based on total injected power required by WTs and BESSs, which is regarded an innovation in this study, on both real and reactive power. In this study, total loss is considered to be both active and reactive. Note that in the sizing optimization problem, a maximum total active and reactive power limit is needed to satisfy demand. As a result of the harmful consequences they release into the atmosphere and water, renewable energy sources are becoming increasingly popular as a means of reducing emissions and the subsequent increase in global warming. The most common renewable energy sources are wind turbines and solar photovoltaic (PV) systems. On the other side, there are disadvantages to using renewable energy sources. Uncertainty in the amount of electricity that can be generated by renewable energy sources is their main drawback. It is hard to maintain equal generation and demand due to the inconsistency of renewable energy sources and the quick increase or decrease in demand. This means that voltage and frequency on the grid will be out of whack, causing operational difficulties and perhaps threatening stability. BESS (battery energy storage systems) can be used to regulate the production of renewable energy sources and to stabilize the grids. It is possible to store energy

in batteries. Battery energy storage systems are rechargeable battery systems that store energy from solar arrays or the electric grid and provide it to a home or business. Peak shaving and load shifting, which were previously difficult or impossible to accomplish with standard batteries, are now simple tasks that can be accomplished with them because to their advanced technology (Goel & Billinton, 1994; Kannan et al., 2005; Niknam & Doagou-Mojarrad, 2012; Shaaban et al., 2013; Sullivan et al., 2009).

Using a battery system, a solar and wind power plant's generated energy may be distributed and controlled. Storage of solar and wind electricity during periods of high grid demand may be possible in the battery system. Later, the battery's stored energy can be used or sold. It will also smooth out short-term variations in energy generation that are brought on by weather changes. A battery storage system's main components are the battery, monitoring and control systems, and a power conversion system. In a cell-based battery, individual cells are connected to create modules, which are then combined to form packs of energy storage. An electrolyte flows through a reaction stack in a flow battery, which is made up of external tanks. In order to maintain safety and maximize performance, the battery management system, which comprises monitoring and control systems, is essential. Each cell in the battery is protected from overcharging and is regulated by the battery management system. In terms of both health and productivity, this is a necessity. Depending on the type of battery cell or component being monitored, there may be specific issues that must be addressed. Prioritizing thermal monitoring and control of lithium ion battery packs is essential because of their propensity to overheat. Many of the newest devices on the market include a storage system that is also connected to an inverter, resulting in a single integrated solution. An "energy storage system" (ESS) is a technology that transforms electrical energy from power systems into a form that may be stored for future use. Systems that use rechargeable batteries to store electricity generated by solar panels or the grid are known as battery energy storage systems (BESS). As well as deliver it to an individual or business. Because of their advanced technology, they are able to do tasks that were previously difficult or impossible, such as peak shaving and load shifting, more easily than standard batteries.

In order to discover relevant studies, we utilized a search term that includes both "energy storage" and 'reliability' in the title and abstract. We looked for journals that published papers on energy, energy conservation, energy management, and engineering, among other topics. Articles were included even if they were published in low-quality journals since a wide range of

data formats is necessary for a complete understanding of the phenomena of interest. However, except from journals and conference proceedings, we did not include any additional publications in our study. Using a combination of battery energy storage (BESS) and compensators, a wattage and volt-amp reactive (VAR) planning approach was created to address network susceptibility to voltage drop and system inefficiencies. The suggested system's advantage will next be determined by evaluating the most cost-effective combination of BESS and shunt capacitor bank.

While researching the reliability of grid-scale battery energy storage systems, this document provide an overview of the components and failure scenarios to keep in mind (BESS). This includes failures of the primary component as well as faults in the protection and communications systems. Qualitative fault tree analysis (FTA) based on Boolean logic is offered as a framework for subsequent investigation after all failures have been identified. Storage facilities may be used for a number of reasons, each of which requires a different level of reliability. Applications covered in the research include boosting supply dependability, compensating power flow management, market participation, and frequency regulation. Matlab/Simulink is used to model a microgrid, which contains a PV for solar electricity and a WECS (Wind Energy Conversion System). With the addition of a Battery Energy Storage System (BESS), a Hybrid Distributed Energy Resource (HDER) is created. Multiple test scenarios are simulated, each with a unique set of circumstances. Single line-to-ground and phase faults were used as models in this investigation. Using the t-test analytical technique, this study will show if a battery will actually support the performance of the microgrid system, how much it will contribute, and what type of circumstance where the It demonstrates that battery-powered devices have a distinct advantage over their non-powered counterparts.

Ongoing reviews aim to examine and gauge the effectiveness of currently deployed technologies as well as those yet to come. As a result of a thorough review of the literature and previous research, the economic and environmental obstacles, challenges, and restrictions have been produced. SMES, FES, PHS, TES, CAES, and HES (Hybrid Energy Storage) are a few of the technologies discussed. Energy storage systems for grids and other applications, such as machines and portable devices, can benefit from the information in this article, which may be useful to policymakers and practitioners. Nickel-cobalt-manganese oxide chemistry was employed in this work to model an equivalent circuit battery. Lithium-ion battery energy storage system while taking into accounts all of the aspects

impacting its performance. In the Matlab/Simulink platform, a battery cell model was created, and then an algorithm was created to build an acceptable size of lithium-ion battery energy storage systems. The developed algorithm was applied using real data from a harbor grid in the land Islands and the simulation results validated that the sizes and locations of battery energy storage systems are accurate enough for the harbor grid in the land Islands to meet the predicted maximum load demand of multiple new electric ferry charging stations. The paper investigates the effect of the BESS's charging and discharging characteristics on its operation, studying the storage unit's behavior for the specified operating plans. The last step in the analysis is to regulate the power flow in the private network. The functioning of the VPP [Virtual Power Plant] was investigated for the specified scenario of power flow regulation. The scenario's goal is to adapt the private network's load to the level specified by the function. The power flow tests are performed on the day when the largest power demand occurs. The study was carried out for four cases: a constant value restriction while the HPP [Hydro Power Plant] is in operation and when it is not, and two limitations determined by function when the HPP is in normal operation. Thus, the paper addresses not only the problem of establishing the actual charging and discharging characteristics of the storage unit, but also their influence on the overall functioning of the VPP (Chen et al., 2011; Gaun et al., 2010; Goswami & Basu, 1992; Manwell et al., 2006; Xiao, Bai, Li et al., 2014).

This research describes BESS an efficient method for allocating and scaling energy storage devices in order to increase the dependability of a hybrid radial distribution system. The suggested optimum ESS planning is provided with an objective function that includes the cost of energy not supplied (CENS), ESS investment and operating costs and power loss in the distribution system. To minimize the objective function, the particle swarm optimization (PSO) approach was used. Several case studies on an 11 kV, 30 bus radial distribution system are used to demonstrate the suggested technique. The article also demonstrates the success of ESS installation in terms of both technical and economic elements of the system. Furthermore, a thorough sensitivity analysis is carried out by restricting the number of ESS and candidate buses to be used in conjunction with ESS.

Energy management

Microgrid energy management (MGEM) is described as mixed-integer linear programming in this study, and a novel multi-objective solution for MGEM, together

with a demand response programme, is provided. The optimization challenge includes demand response to illustrate its influence on optimum energy dispatch and techno-commercial advantages. For effective ESS scheduling, a fuzzy interface has been created. The value of a BESS has been examined in this study for system reliability enhancement while executing energy arbitrage. While performing energy arbitrage, the goal of maximizing revenue from the energy market has been emphasized. Tracking the BESS's state of charge resulted in the development of a multi-state model. The BESS states have been modelled as both generators and loads for generation adequacy evaluation, since they provide electricity to the grid when discharging and demand power from the grid while charging. The categorization was done based on the device's SOC for a certain hour. The increase in reliability has been shown in terms of the different reliability indices gained is the building of the generation reserve model. The IEEE Reliability Test System was utilized to establish the suggested model's validity. The findings reveal that the system's dependability improves significantly in the presence of the BESS.

This paper provides a survey of the literature on the converter topologies typically used in BESS linked to MV grids. In addition, a case study is carried out to examine various converter topologies for connecting the BESS to the grid. It can be concluded that, although the two-level and three-level topologies need a step-up transformer for connection to the medium voltage grid, resulting in larger losses, they are still superior to the MMC [Modular Multilevel Converter] topologies owing to their physical and control simplicity. However, because of the lower losses and higher reliability, it is conceivable to confirm a developing trend of employing MMC topologies in BESS applications.

When an electrical system's transmission capacity is inadequate to meet consumer demand, the transmission system is said to be congested. To enhance capacity, more transmission lines may be added. Transmission congestion, on the other hand, often happens only during peak demand periods, which occur only a few times per year; capital-intensive expenditures in additional transmission capacity address issues that occur seldom. Alternative solutions to transmission congestion have been developed, including as generation reduction, demand response programmes, and different corrective action schemes. Though not a typical option at the moment, battery energy storage solutions may help alleviate transmission congestion.

This research described an innovative approach for combining the planning and scheduling of BESSs put in an LV grid. As a result, BESS sitting and sizing are

carried out with the assistance of a particular evaluation of system functioning. The suggested method combines the qualities of metaheuristics used to search for solutions in a large space (for the formation of planning alternatives) with the quick computation of the greedy technique, which enables a feasible solution for BESS scheduling to be identified. This technique allows us to overcome the barrier imposed by the intractable total number of BESS size combinations while also dealing with the non-trivial operational concerns associated with fluctuations in time of power flows in the network and BESS scheduling. Furthermore, the uncertainty associated with future possibilities was addressed using a decision theory-based strategy.

This paper describes BESS how high PV penetration contributes to system losses in a distributed power network and how it may be mitigated by effective deployment of battery energy storage devices (BESS). As a result, a genetic algorithm-based optimization approach has been developed to efficiently construct an appropriate BESS location in order to greatly minimize the total system losses associated with the integration of a high penetration level of solar photovoltaics. The suggested methodology's efficacy and resilience have been compared tested and confirmed on a variety of situations caused on the IEEE 33 bus system. Furthermore, a quantitative comparison of aggregated and dispersed BESS installation configurations is investigated. The findings verify a considerable decrease in system losses of 40.51 percent and 57.68 percent, respectively, in aggregated and distributed BESS scenarios.

Based on the findings of laboratory experiments, this study proposes a technique for battery modelling. The authors' key contribution was an examination of the main limitations and consequences of each parameter of the battery model on its behavior and lifespan. This may assist to increase the model's accuracy. The Kinetic Battery Describe serves as the study's foundation due to its ability to model both the recovery impact and the rate-capacity effect. The results of the experimental tests are utilized to carry out the analysis and to create the BESS approach for identifying the parameters of batteries. These latter may be used to anticipate and estimate battery lifespan based on real operating circumstances, which is very useful in microgrid and distributed systems.

Based on a modest 7-bus case study system, this research demonstrates the contribution of an Energy Storage System to power system inertia through Stochastic Unit Commitment. As envisioned, the Energy Storage System adds inertia to the system in an efficient manner, keeping the system frequency characteristics within a reasonable range. Furthermore, the

usage of ESS is less expensive than the cost of including inertia limits into unit commitment, and generators will not be committed for the sole purpose of inertia, which is already provided by the Energy Storage System.

An detailed literature review on optimum ESS allocation and control is conducted in this work. Furthermore, several technologies and the advantages of the ESS are examined. There are also some case studies of ESS use in various parts of the globe given. Finally, this article stresses the future enhancement of ESS management and performance in order to tackle increasingly complex difficulties arising from the inclusion of renewable energy production in the system. The focus is on the most effective ESS location, size, and control mechanisms. The created techniques are thoroughly examined in terms of their goal functions, applications, advantages/disadvantages, test system kinds, and soon for the power system.

A new optimization formulation based on a genetic algorithm for simultaneous sizing and placement of BESSs and WTs in a power system, resulting in the BESS location and size (capacity) of WTs and BESSs in a power system by minimising total system loss (active and reactive loss) and WT and BESS costs, thereby improving demand bus voltage profiles. The solution to the optimization issue is the ideal buses for locating WTs and BESSs, as well as their size (installable active and reactive power). The case studies done on the IEEE 33 bus system verify the formulation's applicability for loss reduction and improving bus voltage profiles in the test system in the presence of WT and BESS.

An ideal location method is used for battery storage and PV production to be more accessible for both the load and NB-S units during severe events, with the goal of improving system resilience. We presented the ideas of reachability and capacity accessibility index to assist in selecting certain essential buses and structuring the goals in a multi-objective size and location optimization paradigm. The numerical tests show that certain buses are much more essential than others, since the resources allocated on those buses are more approachable by the loads or NB-S units during intense events of varying intensities. When compared to alternative placement schemes, the system performs better in terms of load pick-up and the B-S process excursion when using the suggested optimum size and location plan. When the contingency is more severe, the disparity becomes more apparent.

Mechanical EES, electro-chemical/electrical EES, and alternative fuel EES are the three types of EES technologies studied in this research. Mechanical EES is often based on bi-conversions of electrical and kinetic energy, some of which are achieved by varying the internal

energy of a working medium (e.g. water, air and rocks). Pumped hydro energy storage (PHES), compressed air energy storage (CAES), liquid air energy storage (LAES), thermal energy storage (TES), gravity energy storage (GES), and flywheels are all examples of mechanical EES that were studied in this research. Reversible electrochemical reactions or electrical capacitive processes are often used in electrochemical/electrical EES. Lithium-ion batteries (LIB), liquid metal batteries (LMB), redox flow batteries (RFB), and supercapacitors are among the EES that were investigated in this research. The majority of alternative fuel EES is based on reversible electrochemical processes that complete a non-fossil fuels reduction and oxidation cycle. Electricity is utilized in the EES to create alternative fuels that are both storable and transportable energy carriers with high energy densities. The electro-synthesized fuel might be consumed (i.e. oxidized) at a location other than where it was synthesized, possibly supplying a broader range of energy demands as a fuel across many locations.

This research developed an optimization approach for determining the appropriate capacity and placement of ESS units in a smart distribution network while taking DRP [Distributed Resource Planning] impacts into account. This research analyses and explores the influence of BESS on distribution network stability with high levels of inverter-based DG adoption. The observed findings demonstrate that correct BESS charging and discharging strategies may improve network transient stability. Fast switching between charging and discharging modes would be beneficial during transient fault disturbances in order to maintain the system balanced (Atwa et al., 2011; Hetzer et al., 2008; Nagarajan & Saravanan, 2014; Xiao, Bai, Lu et al., 2014; Xiao et al., 2012).

A technique is used for determining the appropriate position of BESS for improved supply continuity and to facilitate the integration of renewable energy and distributed energy resources. The approach is used to a real-world network instance to compare the BESS position of BESS in the transmission or distribution grid. In this study, a DC/AC microgrid with PV power production and BESS for dc and ac load applications is investigated. Control techniques for BESS regulation converters and grid-connected bidirectional active rectifiers are intended to meet power management requirements. The BESS reserves electricity produced by the PV plant, allowing it to operate at full capacity under peak load demand. Similarly, the grid may be utilized to help the system by providing more active power to the load. In this manner, the electricity generated by the PV system is effectively utilized to maintain the system's

energy management. The DG grid interface system acts as an interface between the grid and different forms of linear and non-linear loads, accurately adjusting the source current, reactive power, and soon.

TES is an essential component of the power system. TES systems might recover waste heat and intermittent renewable energy to address the mismatch between power production and customer demand, seeking to increase energy utility efficiency and minimize greenhouse gas emissions. To modify the produced electricity from solar thermal, TES has been frequently incorporated into Concentrated Solar Power (CSP) systems as storage. Furthermore, TES is critical in CAES and LAES for increasing RTE and lowering carbon emissions. Heat may also be employed as an energy form to complete the electrical energy storage process, allowing TES to function as stand-alone EES systems for power-to-heat and heat-to-power conversions. During the charging phase, electricity is stored in the form of heat, sensible heat, latent heat, or chemical reaction products; then, during the discharging period, the stored heat is released to drive a heat engine for power production. Two kinds of TES technology are often used in standalone EES applications.

Using the Particle Swarm Optimization (PSO) technology, this work provided a method for determining the BESS position and size for installing BESS in a microgrid. In this research, wind and solar power were the dominant sources of energy production. The IEEE 14 bus system was employed, and the system was simulated using the MATLAB software. According to the modelling findings, putting BESS in an ideal position decreased the consumption of power loss in the microgrid. The optimal size installation gave the capacity to charge and discharge enough power to all loads to maintain the voltage throughout the whole bus in a day. In addition, the cost of investment was decreased as a result of the BESS's sub optimal size.

The purpose of this research is to give a comprehensive and systematic analysis of the reliability consequences of energy storage technologies in this industry. To begin, data show that energy storage use in power networks is important in enhancing system dependability and lowering transmission upgrade costs. Second, regulations that encourage the use of renewable energy rather than fossil fuels have a favorable impact on the development of energy storage systems. Third, North America was an early pioneer in the study of power system dependability and energy storage systems. However, Asia has lately assumed the position, with China serving as the primary engine. There are also research gaps in this topic. This review may help researchers advance their theoretical

knowledge of the reliability consequences of energy storage systems and fill gaps in the area.

Energy storage systems (ESSs) may improve energy network performance in a variety of ways, including compensating for the stochastic character of renewable energies and facilitating their large-scale incorporation into the grid environment. Energy storage alternatives may also be employed for the efficient functioning of energy systems, lowering system running costs. It is quite feasible to store energy at a cheaper cost during off-peak hours and recharge the grid during peak load times while avoiding large price spikes by deploying ESSs. The use of ESSs will also improve the usage of distributed energy sources and allow more controllability at the supply/demand side, which will be useful for load levelling or peak shaving. This research focuses on these concerns and presents a broad framework for optimizing the design and operation management of battery-powered ESSs in energy networks.

Specifically, several models are investigated: an average model represented by voltage sources; an ideal dc source behind a voltage source converter; a back-to-back buck/boost and bi-directional three phase converter, with all models sharing the same control system and parameters; and two additional proposed models in which the switches are replaced by dependent sources to help analyse the differences in model performance. All of these models are created in PSCAD, and their performances are simulated and evaluated in a benchmark test microgrid, taking into account factors like as voltage and frequency stability, as well as total harmonic distortion. Simulation findings and eigenvalue tests reveal that the suggested models may operate differently, particularly when the system is substantially loaded, underscoring the necessity for more accurate modelling under specific microgrid settings (Niknam

& Doagou-Mojarrad, 2012; Shaaban et al., 2013; Sullivan et al., 2009; Wacker & Billinton, 1989; Wang et al., 2009).

Battery energy systems

The purpose of this study is to offer an overview of ideal ESS location, size, and functioning. It takes into account a variety of grid situations, intended performance targets, applicable techniques, ESS kinds, and the benefits and constraints of the suggested systems and methodologies. While batteries are commonly employed as ESSs in a variety of applications, a rigorous comparative examination of ESS technical attributes indicates that flywheel energy storage (FES) should also be considered in certain distribution network situations. This study recommends associated requirements or processes, proper ESS selection, smart ESS charging and discharging, ESS size, location, and operation, and power quality concerns.

A two-stage BESS is conceived and implemented in this research. In Stage I, a modular design is utilized to aggregate numerous battery sets, and one BMS is connected with one aggregated battery module; in Stage II, one PCS is used to link each aggregated battery module to the external grid or a microgrid's PCC. Because the aforementioned modular BESS uses fewer BMSs and PCSs, the system cost may be reduced. Meanwhile, from the inverter control perspective, SoC balancing is accomplished in each aggregated battery module to equalize charging and discharging power across several battery sets. Meanwhile, an additional virtual impedance loop is used in Stage II to simplify the integration of numerous PCSs and to alleviate resonance concerns is shown in Figure 2 (Niknam & Doagou-Mojarrad, 2012).

The paper presents heuristics for behind-the-meter BESS placement and sizing, forecasting, and dispatch in order to manage violations and maximize self-

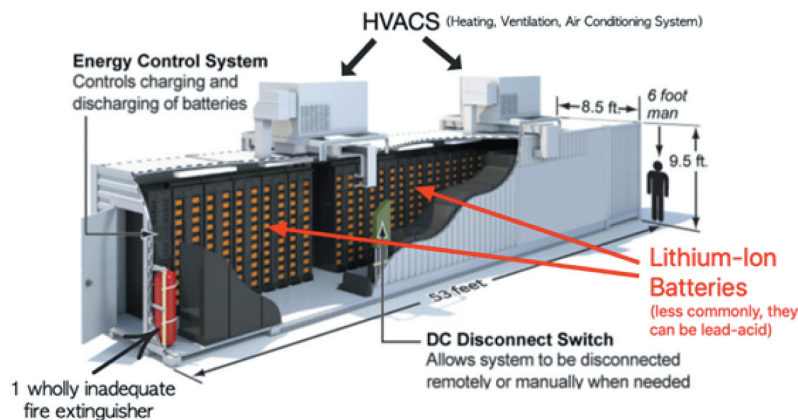

Figure 2. Battery energy storage system [25].

consumption. The heuristic findings are examined through the eyes of a DNO who pays for and install BESSs or pay a third party to acquire, install, and operate BESSs. The remaining system costs are compared to the costs of reconductorizing, and it is clear that in the case studied, reconductorizing is the less expensive option in all modelled scenarios. The findings indicate that a similar conclusion is anticipated for the majority of short urban feeder test cases, but it is uncertain if the same results can be attained for longer feeders that may need additional reconductorizing. More research is needed to examine the sensitivity of findings to network architecture as well as different BESS ownership and control structures.

Looking at previous works on ESSs and power system reliability, we see gaps in the literature that future research can fill. Future study, for example, could look at other renewable energy sources outside wind and solar energy. To the BESS of the authors' knowledge, modelling on other energy sources is limited. As a result, future research can concentrate on developing accurate and efficient models of these sources in order to advance reliability studies. Aside from that, further study might look at the dependability consequences of hybrid energy storage in current power networks. In terms of technical advancement, hybrid energy storage is now advancing quickly. However, it is currently insufficiently compelling to be used in real-world applications. In the future, experts may investigate its influence on power system dependability to help utility operators make decisions.

This recovery time at the generator bus is compared in this article for different battery energy storage system (BESS) deployment techniques. The results reveal that a voltage sensitivity-based algorithm allows grid-compatible recovery for numerous distributed generators (DG) in a renewable integrated microgrid. Three BESS placement methods were investigated in this research, and their impact on post-fault voltage recovery was investigated. In a renewable integrate dislanted microgrid system, a comparative study was conducted. The results reveal that, of the three algorithms, BESS, when put on the most voltage sensitive bus, provides rapid and grid-compatible voltage recovery at all generator terminals. Future study would focus on developing the analytical analysis that underpins the higher performance of voltage sensitivity based BESS placement.

The research provides a Mixed Integer Optimization with Genetic Algorithm (MIOGA) method for calculating the optimal sizes and placements of Battery-Sourced Distributed Photovoltaic Generation (B-SDPVG) plants in distribution networks to minimize total energy losses.

The sizes of the PV plant, battery storage, and optimal levels of energy demand were calculated dynamically in the proposed framework. As the primary objective function for the optimization problem, the Total Energy Loss Index (TELI) was modelled. The battery-sourced distributed photovoltaic generation (B-SDPVG) plants' bus voltage variations and penetrations were also determined. 15 years of meteorological data were modelled using the Beta Probability Density Function to analyze the stochastic behavior of solar irradiation (Beta-PDF). The suggested technique was tested on IEEE 33 bus and IEEE 69 bus test distribution networks, yielding optimal results for various time varying voltage dependent load models.

The BESS position and size of a BESS for voltage control in a distribution system while boosting battery longevity are discovered in this research. Various elements affecting a battery's longevity are addressed and modelled. The issue is written as a multi-objective optimization problem with two objectives. The first goal function computes the system's energy losses, while the second objective function reflects the overall investment cost of the distributed generator (DG) and BESS installations. Wind and solar DGs with unpredictable output power are also taken into account by the BESSs. To tackle the optimization issue, an elitist non-dominated sorting genetic algorithm-II with a utopian point technique is applied. This research also takes into account an IEEE 906 bus European low-voltage test feeder and eight test cases. The findings demonstrate lower losses and costs, an improvement in the voltage profile, and a longer battery lifetime.

This research looked at the impact of ESS utilization on energy generating costs in networks over a certain time period. This involves selecting the optimal site for the ESS's installation as well as the BESS feasible operating schedules for the ESS and power plants in order to achieve the biggest reduction in daily energy generating expenses. Under various circumstances, the effects of all elements influencing the final result were investigated. The consequences of different power plant cost functions, transmission line capacity, and network enhancements were compared. All scenarios were realized in a 30-bus IEEE standard network. For specified power plant cost functions, the greatest available ESS characteristics may lower daily energy generating costs by 3%. It was discovered that using ESS in a network reduced stress on the transmission line, allowing the network upgrade to be postponed for 21 years.

This paper tackles the challenge of generation coordination of distributed energy resources and battery energy storage system (BESS) in a grid-connected micro-grid in order to reduce the micro-overall grid's

operating cost. In a microgrid, a mix of dispatchable and non-dispatchable generators, as well as BESS, is considered. A novel method of individual coding is offered. A change is also proposed in fundamental elephant herding optimization (EHO). The suggested modified EHO (MEHO) and EHO are used to solve the optimization issue, and the MEHO findings outperform current swarm-based strategies. The solution suggested in this paper has the ability to address the complicated microgrid scheduling challenge. In this study, a deterministic model of the issue is simulated; nevertheless, many uncertainties such as renewable DGs, load, market pricing, and so on must be taken into account. To account for these uncertainties, a stochastic model of the issue must be built, which is a future goal of this effort.

This study gives an updated assessment of the literature on optimization approaches used for the size and energy management of hybrid photovoltaic/wind/battery energy systems. Furthermore, for grid-connected hybrid energy systems, a novel scaling strategy based on the cuckoo search (CS) algorithm is suggested. The optimization of size is a multi-objective issue involving economic, technological, and environmental limitations. A unique grid power absorption probability (GPAP) parameter is used to simulate the reliability requirement. The novel approach is being tried for both a residential load and an agricultural farm load in Ghardaia, Algeria. When compared to the particle swarm sizing optimization (PSO) methodology, the suggested method has higher accuracy, quicker convergence, and less computing time.

The purpose of this article is to look into the impact of a battery energy storage system (BESS) on the post-fault frequency state of an islanded system. The studies compare the placements of BESS at several grid sites, such as the point of common coupling, the bus with the highest load, and the bus with the lowest load is shown in Figure 3 (Chen et al., 2011). The results reveal that BESS minimizes post-fault frequency variations at the

site of common coupling in the fastest and most efficient way. This research demonstrates the importance of BESS deployment and rating in achieving adequate frequency management of an islanded microgrid. In contrast to other accessible sites, the results show that BESS at the PCC of the DG unit offers substantial help in decreasing post-fault frequency variation. Future study will concentrate on building a mechanism for selecting the BESS grade for frequency control.

Storage systems are vital to the distribution system because they supply active and reactive power to increase both the angle and magnitude of the voltage, absorb surplus power, and provide power assistance when needed. Storage devices, on the other hand, are costly and cannot be put on every node in the system. It is vital to choose the BESS position for a storage system that will have an influence on the whole system. Sensitivity indices are suggested in this work for analyzing the BESS placement for the storage system.

The application possibilities of energy storage technologies are evaluated and researched, and potential markets for energy storage applications in the global and Chinese markets are discussed. The limitations of large-scale energy storage use in power systems are discussed from both a technological and economic standpoint. Meanwhile, the worldwide energy storage market's growth prospects are anticipated, and the application prospects of energy storage are examined.

In the future, such a technology might be extensively used in coastal regions and on islands. A historical multiple state probability model of a tidal power generation system (TPGS) is created, taking into account both the TPGS's forced out aerate (FOR) and the random character of tidal current speed. The provided power related failure rates of power electronic converters for TPGS and WPGS (wind power generation system) are evaluated in the assessment of FORs of TPGS and WPGS (wind power generation system). A battery energy

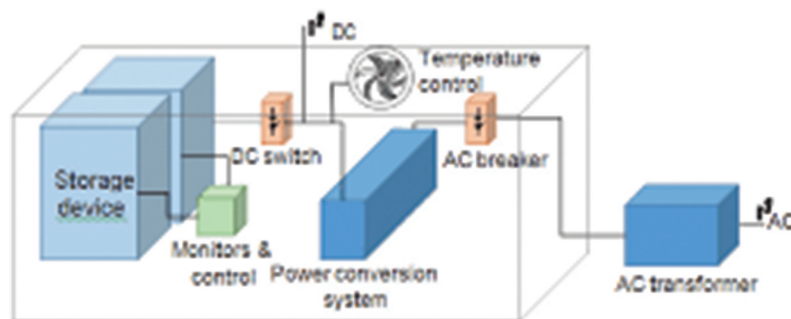

Figure 3. Primary components of battery energy storage system [28].

storage system (BESS) chronological power output model is developed. To demonstrate the efficacy of the proposed technology, a hybrid system of tidal and wind production powers with a BESS is employed.

The outer optimization evaluates the BESS location and capacity for BESS with the goal of lowering the total net present value (NPV) of the distribution network throughout the course of the project's life cycle. The inner optimization then implements optimum power flow (OPF) and BESS capacity modification. OPF optimizes BESS scheduling and network losses. On the basis of optimum BESS scheduling, a new capacity adjustment approach is presented to obtain the ideal BESS capacity while taking battery lifespan into account in order to minimize the NPV of BESS. Finally, the suggested technique is tested on a modified IEEE 33-bus system and shown to be more effective than an existing method that does not use BESS capacity adjustment.

The application possibilities of energy storage technologies are evaluated and researched, and potential markets for energy storage applications in the global and Chinese markets are discussed. The limitations of large-scale energy storage use in power systems are discussed from both a technological and economic standpoint. Meanwhile, the worldwide energy storage market's growth prospects are anticipated, and the application prospects of energy storage are examined.

The function of energy storage systems (ESS) is recognized as a means of providing greater system security, dependability, and flexibility to adapt to changes that are still difficult to predict. However, there are still unanswered concerns about the advantages these units provide to the generating side, system operators, and consumers. This paper gives a complete analysis of existing ESS allocation research (ESS size and siting), providing a unique insight into the concerns and constraints of integrating ESS into distribution networks and thereby providing framework recommendations for future ESS research.

The created framework is shown on a modified IEEE (Institute of Electrical and Electronics Engineers) 24 bus RTS (Reliability Test System), and the framework determines the ideal allocation solution as well as the profits earned at each of these places. CAES (compressed air energy storage) is selected as the typical storage technology, and the advantages of appropriately allocated storage integration into the grid are compared to transmission extension solutions. We offer a DC optimum power flow (OPF) paradigm for storage portfolio optimization in transmission-constrained power networks in this research.

This model is specifically designed to study two issues

- (i) Improving storage operation and allocation throughout a network with a set technology portfolio, and
- (ii) Optimizing the storage portfolio (i.e. the size, technology, and network allocation of these resources).

This framework is shown via case studies based on the IEEE 14-bus test system and four distinct storage systems. Our findings reveal that, although some technologies are often categorized as being suitable for either power or energy services, many technologies may contribute value to the system by performing both fast-time scale regulation (power) and load-shifting (energy).

The suggested technique takes into consideration voltage support and network losses, as well as the cost of electricity from the external grid and congestion control. The selection of the solution approach is a non-trivial challenge in the case of large-scale problems, accounting for networks with a significant number of nodes and scenarios. In this regard, the article presents and explores the usage of the Alternative Direction Method of Multipliers to define an efficient algorithm capable of treating large-scale networks, as well as addressing the question of the solution's optimality.

In this research, the ESS attempts to reduce wind power changes between two rolling Economic Dispatches (EDs) in order to preserve generation-load balance. The charging and discharging of ESS is optimized by taking into account the operating costs of conventional generators, the capital cost of the ESS, and transmission losses. The facts from simulated system operations are then combined with the planning process to determine the appropriate placement and size of storage units throughout the network. An IEEE benchmark system is used to study these problems. In the context of renewable energy and dynamic pricing associated with grid power, we address the optimum energy storage management and size issue. We model the issue as a stochastic dynamic programme with the goal of minimizing the long-run average cost of power utilized and, if any, investment in storage while meeting all demand. We simulate storage using ramp limitations, conversion and dissipation losses, and an investment cost.

Furthermore, the dependability of the power system will be assessed utilizing an integrated battery energy storage system and a wind farm. Growing demand for electrical energy, the steady depletion of fossil fuel supplies, and environmental contamination as a result of their continued exploitation have all necessitated a shift

in energy sources used in power production. The power production of a wind farm fluctuates due to the random nature of wind speed; as a consequence, it lacks effective control capabilities. The increasing penetration of wind power production in the electricity system may pose a variety of issues in areas such as power quality, system stability, and dependability. Using Energy Storage Systems (ESS) is a way for dealing with the fluctuating nature of wind turbine power

The goal of this research is to improve power system resilience by proposing an optimum size and location plan for battery storage and photovoltaic (PV) generating. To assess the reach- ability of power and energy capacity during severe events, the concept of capacity accessibility for both electricity demand and non-black start (NB-S) producing units is presented. [Furthermore, system architecture and how it might be used for monitoring and control are highlighted. A route for developing BMS in order to better leverage BESS for grid- scale applications is provided. The paper concentrated on the development of an effective planning approach for the placement and size of DSSs in order to maximize their impact in terms of voltage support, loss mitigation, and energy cost from the grid to active distribution networks. The research focuses on the subject of optimum distributed storage system siting and size. The research suggests, in particular, the formulation of a problem that accounts for i) the voltage support of storage systems to the grid, (ii) network losses, and (iii) the cost of energy-flow towards the external grid. Because the defined issue is mixed- integer, non-convex, and non-linear, it necessitates the use of heuristic approaches to solve (Atwa & El-Saadany, 2011; Goel & Billinton, 1994; Hegazy et al., 2003; Kannan et al., 2005; Yan et al., 2009).

The sensitivity index for each bus in the system is used as a consideration in determining where the BESS should be placed in the system. The phase wise sensitivity index, rather than total sensitivity, should be used to find the BESS location for the BESS. The suggested technique enables the power system designer to put the BESS in the order of priority, i.e. from the most negative sensitivity bus to the least negative sensitivity bus. In addition, the study presents a technique for determining the BESS power to be delivered/absorbed by the BESS under different operating situations. IEEE test bus systems were used to validate the suggested method. In the example of a 34-bus system, the overall system loss was minimized by using BESS and a wind generator, as well as improving the voltage profiles of the individual buses in the system. Over a multi-year planning period, the optimization seeks to minimize the total of the expenses borne by the distributor for power

losses, network upgrades, reactive power service provision, and storage and capacitor installation. A hybrid technique was utilized, which was based on a genetic algorithm and a sequential quadratic programming-based algorithm. To demonstrate the viability of the suggested approach, a numerical application on an 18-busbar MV balanced 3-phase network was done.

Following a study of the literature on energy storage use in the power system dependability sector, we discovered flaws and holes that future research might fill. To begin, future research should focus on the potential of utilizing this technology in sectors located in developing and underdeveloped countries, as access to electricity remains limited in these areas, and the development of energy storage facilities as a body of knowledge can help to address this issue. For example, although Asia has provided the most articles, the majority of their research originates from China. There is still a significant gap in academic engagement from other areas of Asia, notably Southeast Asia. Future study should cover different forms of renewable energy. Currently, studies mostly rely on wind and solar energy, and a major gap defines the search for other possible renewable energy resources, most likely owing to a lack of research into models and technologies capable of converting and integrating these resources into systems.

Future study should look at the feasibility of using hybrid energy storage devices for dependability studies. To the BESS of the authors' knowledge, there is a lot of interest in hybridizing ESS in terms of technical development and modelling. Finally, research on the integration of smart solutions with ESS is still in the early stages and may be expanded. The usage of automobiles as a form of transportation is rapidly expanding, and V2G is a smart and green option for peak shaving and may improve renewable integration into distribution networks.

Microgrid technology issues and challenges

Batteries, for example, can absorb and equalize power transmission variations induced by the production of solar energy. Although this technique reduces transmission infrastructure capacity, it also increases the cost of enormous accumulators because of the need for them. It follows that unless storage devices become significantly more affordable, we won't be able to apply this method. Then we can add gas turbines, which allow us to swiftly change the output power of the machine. For example, the integrated plant is able to absorb PV output changes in order to increase the transmission operation ratio. It does, however, demand the construction of a thermal power plant in parallel with PV, which is a diversion

from our original goal of adopting a large amount of PV. Even in a calamity, the DC micro grid can handle it. Even if we don't have outside access to electricity or fuel, we can still have electric power sources. During power outages, the DC micro grid functions as a stand-alone power source that is not connected to the main power supply grid. Since power is distributed to loads via conventional distribution lines, emergency-only lines aren't necessary. In order to protect their independence, residents of the same community will work together to maximize the amount of power that is accessible to them.

It is a system of low-voltage power distribution that incorporates distributed generation, energy storage, and loads. It's the most efficient way to decentralize the electricity grid. More reliable systems, reduced investment costs, a greener system owing to renewable sources, greater power quality and fewer distribution network losses emerge from the microgrid's intrinsic flexibility to be linked and removed from the main grid. A microgrid can be divided into three kinds based on its topology: AC, DC, or hybrid. The AC microgrid is the most prevalent configuration, as it makes use of current grid infrastructure, protection, and technology. On the downside, synchronization of DG units and reactive power circulation losses are required. Since DC sources must be converted to AC before being used, this reduces overall efficiency. The increasing penetration of DC-based distributed energy resources, such as photovoltaics and fuel cells, energy storage systems, and loads has made DC microgrids possible. In order to do so, however, the current electrical grid must be drastically altered. Individual AC and DC microgrids are wasteful as a result of the numerous DC/DC, AC/DC, and DC/AC conversions. The use of a hybrid microgrid to integrate smart grids into existing distribution networks is an excellent idea. Microgrids based on alternating current and direct current can now be used to integrate AC and DC-based distributed energy resources, storage systems, and loads directly, without the requirement for synchronization, easy transition, or economic feasibility. There is a lot of room for study in the hybrid microgrid. The most recent breakthroughs in the field of hybrid microgrids necessitate a comprehensive literature review. Review articles simplify this procedure by summarizing the findings and allowing the reader to uncover existing research gaps. In this article, research on hybrid microgrids is examined from top to bottom, beginning with topology and concluding with optimization and control. As a review paper, this one is unique in that it provides a comprehensive comparison of this review paper with past hybrid microgrid reviews in all of the important

sections, such as issues, optimization, power production and sharing control. This makes it an ideal article for scholars who want to broaden their views, as it offers all of the necessary information. The present challenges in the hybrid microgrid are examined in this paper, along with a comparison of possible solutions and the level of research devoted to each alternative. Additionally, the hybrid microgrid's most recent trends and research gaps will be readily available through this resource. A guiding light for future research necessitates the availability of this specific data.

AC and DC subgrids are linked by interlinking converters and bidirectional power sharing, resulting in increased network security and stability. Hybrid microgrids can be connected to the grid or isolated. To ensure the stability of a hybrid microgrid, there is no frequency support for the AC subsystem and there is no voltage support for the DC subsystem in isolated mode. Hybrid AC-DC microgrids have the following operating challenges. Under varied operational conditions, power sharing compromises the stability of hybrid microgrids. It is dependent on both the AC and DC subsystems because of the power exchange through the interface converter. In hybrid microgrids, droop control for all distributed generators has been the focus of various studies. There are numerous ways in which the authors demonstrate how to manage the converter performance and losses of an AC/DC microgrid using a droop technique. According to research, combining AC and DC subgrids can alter their dynamics, putting the entire system at danger of instability (see, Figure 4 (Xiao, Bai, Lu et al., 2014)). Furthermore, the system's dependability is weakened by the use of a single converter. System dependability can be improved by using several converters, according to the authors. Disadvantages include making the AC sub-grid more susceptible to power fluctuations, which reduces overall efficiency. Energy storage devices are recommended by the authors as a means of improving power transmission across sub-grids. Due to its significant impact on the overall design, communication is a critical challenge in developing a system that is both reliable and efficient. Communication methods such as wireless and optical fiber have been used to help address this issue and have been successful in achieving reliable and efficient operation.

Smart grid microgrids can be of two types: one that relies on communication and the other that doesn't. Using voltage, current, and frequency data from the communication-based system, a distributed control and power management system may be tested for proper operation. Both the safety and the regulation of electricity in a hybrid system are dependent on effective

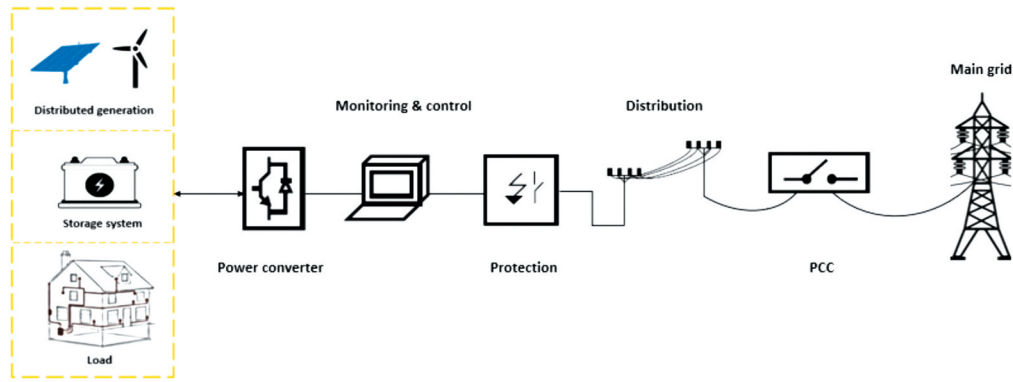

Figure 4. Smart grid challenges [35].

communication. When designing a hybrid AC-DC microgrid system, the interconnected converters' communication infrastructure is crucial. Real-time control and monitoring is challenging to achieve because of the complexity of the system's components. A smart grid's hybrid microgrid development is reliant on communication, system protection, and intelligent coordination among the system controllers.

In microgrids, both AC and DC lines are present. Transmission and dissemination are different for each type. The point of common coupling serves as a passageway between the main grid and the microgrid (PCC). As long as a system's safeguards are functioning properly, an operation will go as planned. Effective monitoring systems and control techniques are used to continuously monitor and regulate voltage, frequency, and power quality. As a result, power converters play a crucial role in grid system conversions between AC and DC or DC and AC.

Solar thermal, PV, wind, fuel cell and biomass are all examples of renewable distribution generating technologies that can be used in microgrids. Non-renewable distribution generation systems can also be used (e.g. diesel engine, stream turbine, and gas engine). In microgrids, for example, solar and wind technologies have grown rapidly and are now key energy sources. To ensure stability, dependability, and overall performance, microgrid storage systems are essential. Storage methods are discussed in this article that can be split into chemical, mechanical, electrical and thermal systems. There are a number of essential energy storage solutions for microgrids that we'll discuss here. Different loads can be accommodated by a microgrid (AC, DC). Load classification is an essential part of the entire microgrid management approach.

With each option, there are advantages and disadvantages to take into account. Microgrid control, protection, and power losses were compared for each form

in. Having the ability to draw energy from the main grid is an advantage of the AC microgrid. In a typical AC microgrid, all variable frequency and voltage sources (such as wind turbines) are connected to the bus via AC/AC power converters. DC/AC converters connect DC-output devices (such as solar panels) to an AC power supply. However, an AC microgrid requires a more complex controller in order to import and export electricity while still maintaining system stability and reliability. When employing a DC microgrid, power sources with DC output are connected directly to the bus, while those with AC output must need AC/DC converters to connect to the DC bus. Therefore, the DC microgrid surpasses the AC microgrid with regard to system efficiency and size as well as investment and operational expenses. Because of its smaller size, the DC system allows for greater overall efficiency and lower power consumption. The DC distribution protection mechanism, on the other hand, is less sophisticated than the AC system. In the future, further research is needed into aspects such as the protection system, architectural design, control methods, and stabilizing ways in the power systems. A hybrid microgrid can provide both AC and DC loads because of its hybrid AC and DC buses.

Numerous methods of optimization have been described in academic literature. A high-penetration distribution system's objective function based on cost-benefit analysis Systems for storing photovoltaic (PV) energy use physical battery models, voltage control, and peak load shaving energy management systems to determine their appropriate size (ESS). More ESS must be installed as PV penetration rises, as seen in the graphs in this study. With the help of wind speed data, we've developed an analysis model that can be used to estimate the cost and utility of an ESS. The findings show that deploying ESS in a power system is not justifiable due to the high cost of ESS installation and the poor

charging and discharging performance. When it comes to finding the BESS location for energy storage systems, an algorithm is proposed that relies heavily on voltage sensitivity analysis and a multi-period optimal power flow framework is used to formulate the sizing problem, with convex relaxations based on semidefinite programming used to solve it with the goal of average network loss, the number of ESS, and the total installed capacity as the primary goals.

Grid-connected PV systems have a few publications on sizing BESSs for the purpose of reducing net power purchase from the grid and battery capacity loss while still meeting demand and reducing peak energy purchase from the grid. For the time-frequency transformation, a power spectrum density of the wind variation was estimated using this method. A method based on long-term wind power time series (WPTS) and the computation of mean wind power, with the charging and discharging cycles of ESS taken into account was used to evaluate the efficacy of ESS in decreasing system costs and losses. Using the Discrete Fourier Transform [DFT], the breaking the required balancing power into various periodic components, such as intraweek, intraday, intrahour, and real-time. Each component can be used to estimate the maximum amount of energy storage required for a variety of storage methods. If a power system is unable to meet this demand, it is beyond its capabilities. It was determined that a microgrid's optimal ESS capacity could be achieved by lowering the overall MG cost, which comprised the ESS investment as well as operational expenses. A Monte Carlo simulation was utilized to account for random uncertainties during the optimization process and to evaluate the MG reliability after MILP was employed to establish the ESS sizing.

Stabilizing and compensating for local power instability has typically required the usage of Energy Storage Systems (ESS). Reactive power support is required in power systems by requirements for system security and operation when renewable energy sources such as wind farms are present. WT must meet particular performance criteria in these standards to ensure that it not only provides active power but also generates enough reactive power to prevent voltage instability and other security concerns. BESS that are carefully sized and positioned to help WTs meet these standard standards may be beneficial. According to the statement, cost-benefit analysis might be used to estimate the real energy storage capability within this range. Linear functions, such as those found in linear programming models, have been advocated by several writers for the allocation of ESS resources. Non-linear AC optimum power flow was transformed into a Linear Programming

problem, which was then addressed by adopting forward backward sweep optimal power flow. When it comes to determining ESS dimensions and location, researchers have relied on mixed integer linear programming (MILP; Banupriya & Nagarajan, 2021; Hannan et al., 2021; Jafari & Botterud, 2022; Ramya & Nagarajan, 2020; Wei et al., 2021).

Artificial intelligence (AI) is a key component of the carbon-neutral society that has attracted a lot of interest from energy supply companies, startups, technology developers, financial institutions, national governments, and the academic community. Examples include self-driving cars, voice recognition-based virtual digital assistants, smart thermostats, and recommendation systems. The emergence of AI opens up a wide range of opportunities for the energy sector to transform into an AI-powered smart system that can revolutionise established methods of creative problem-solving, strategic operation, and operation. This is especially true for hastening our society's transition to a carbon-neutral future. In the Energy Internet (EI), applications of big data analysis support smart energy supply and consumption, smart health, and fintech. This study offers a thorough understanding of these foundational concepts. Then, by carefully examining the literature, we concentrate on making wise decisions for the energy sector and update the state-of-the-art. Following that, new developments in cybersecurity for AI systems connected to EI are reviewed, including vulnerability analysis of AI systems, differential privacy, and blockchain-based security technologies. This is one of the first academic, peer-reviewed publications that, to our knowledge, provides a thorough evaluation of AI applications for EI research and efforts in terms of large data analysis, intelligent decision-making, and AI related cybersecurity. These projects were carefully divided into several categories based on their application, technique, and contribution. Then, possible difficulties, restrictions on current research, and prospects for future approaches are reviewed for a variety of topics, including explainable AI, localised multi-energy markets, self-driving electric car charging, and e-mobility. This study may aid in our understanding of how to create climate-smart cities and essential infrastructure in order to achieve the UN's sustainable development objectives. Fuel cell electric cars (FCEVs), which run on hydrogen, must have access to hydrogen refuelling stations (HRSs). However, the spread of HRSs is challenging because of expensive installation and running expenses. In this study, HRSs with on-site electrolytic production and hydrogen storage devices are examined, and a technique of optimization is suggested to reduce the overall expenses, including installation costs and running costs (OPT-

ISL method). Additionally, this work offers a novel way to simulate refuelling behaviour for various FCEV types and suggests a hydrogen-demand estimate model to predict the need with hourly intervals for HRS in order to get the optimization constraints of hydrogen demand. To confirm the accuracy of the hydrogen-demand estimate, the Jensen-Shannon divergence is used. The outcome of 0.029 is substantially less than that of the estimating technique in the reference. A daily hydrogen production plan is created, together with the ideal electrolyzer and storage device capacity, based on the estimate findings and peak-valley energy rates from the grid. The suggested OPT-ISL technique has the least overall costs, with 8.1 and 10.5% less, respectively, than earlier configuration methods that solely take into account investment expenses or operational costs. The suggested OPT-ISL technique also cuts the HRS's breakeven time in half, from 11.1 years to 7.8 years, a reduction of 29.7%, allowing the HRS to recoup its expenses faster.

Scale-up projects are required for large-scale mechanical storage to quantitatively demonstrate the suitability of decoupled energy and power storage in long-duration storage applications, whereas electrochemical batteries require stable and abundant raw materials as well as scalable approaches to meet the potential massive production demand. • In order for non-battery technologies to be economically viable, better market designs and regulations are required. This may lower investment risk and increase technology adoption for long-term storage applications, ensuring a diverse range of EES applications to suit various electrical demands in the power system. The use of earth-abundant metals in battery chemistries, as well as the reuse and recycling of materials in batteries, may increase battery sustainability. Because the battery industry is quickly expanding, there will be a considerable demand to reuse and recycle batteries. "Second-life batteries" may offer a low-cost supply of LIBs for power systems from electric cars, extending the battery's lifespan value and deferring the expense of recycling. When the battery is built and made, a system of thinking must be created to plan both the "first-life" and the "second-life". EES technology combined with renewable energy power production might provide developing nations a low-cost alternative for improving electricity availability over time. Aside from optimum system designs to reduce system costs, proper business models and maintenance techniques are required to maintain the long-term functioning and beneficial benefits of the distributed energy system (Chaojie, 2021; J. Zhang et al., 2022)

Conclusion and future works

BESS has emerged as a critical component of renewable integrated facility microgrids in recent years. This research demonstrates the importance of BESS deployment and rating in achieving adequate frequency management of an islanded microgrid. According to the collected publications, the use of energy storage in distribution networks is more common than in transmission networks. Microgrids are distribution networks that are primarily designed to serve remote locations. However, recent advances in power system research have permitted the linking of microgrids to distribution networks to construct smart grids comprised of RE sources and ESSs. Other smart technologies, including as real-time thermal rating (RTTR) and demand-side management (DSM) combined with ESS, are now being developed to provide extremely dependable networks. We also see an increase in the use of different strategies to optimize ESS, particularly in terms of capacity size and nodal location. In addition to these optimization approaches, methods that take economic limitations into account, such as model predictive control and stochastic dynamic programming, are discussed. The trend toward maximizing dependability while minimizing net costs is projected to continue.

Most electrochemical batteries, such as LIB, have high energy and power densities, making them suited for usage in quick response services such as primary and secondary response over short periods of time (e.g. half an hour to up to 4–8 hours). Mechanical EES, such as PHES, CAES, LAES, TES, and GES, as well as electrochemical RFB, have lower energy costs due to decoupled energy storage in reservoirs, but typically have lower energy densities than LIBs, making them suitable for large-scale EES applications for seasonal and long-duration storage if sufficient storage reservoirs and space are available. LIBs have lower energy densities than flywheels and supercapacitors, but greater power densities. These two technologies can deliver the quickest response, which might be employed in primary response and network services to ensure high-frequency power quality. EES solutions based on alternative fuels often have high energy and power densities but low RTEs, which are restricted by energy losses in the power-to-fuel and fuel-to-power conversion processes. Alternative fuels have the potential to serve a broad range of power applications in a variety of storage capacities.

Future Projects Looking at prior publications on ESSs and power system dependability, we see gaps in the literature that future study may fill. Future study, for example, could look at other renewable energy

sources outside wind and solar energy. To the BESS of the authors' knowledge, modelling on other energy sources is limited. As a result, future research may concentrate on constructing accurate and efficient models of these sources in order to further dependability studies. Aside from that, further study might look at the dependability consequences of hybrid energy storage in current power networks. In terms of technical advancement, hybrid energy storage is now advancing quickly. However, it is currently insufficiently compelling to be used in real-world applications.

Disclosure statement

No potential conflict of interest was reported by the author(s).

Funding

The authors received no direct funding for this research.

Notes on contributors



K Sushita did her BE degree from Goa University, Goa, India and ME Degree from PSG College of Technology, Anna University, Chennai, India. She is working as assistant professor in the Department of Electrical and Electronics Engineering, Vels Institute of Science, Technology & Advanced Studies (VISTAS), Tamilnadu, India. Her field of interest includes electric vehicle control and charging, neural networks and fuzzy logic control, motor drive, and power converter. She can be contacted at email:sushita.se@velsuniv.ac.in.



N Shanmugasundaram received his BE in Electrical and Electronics Engineering from Anna University, Chennai, India. He did ME in Power Electronics and Industrial Drives from Sathyabama University, Chennai, India and PhD in Electrical Engineering from Anna University Chennai, Tamilnadu, India. He is working as an associate professor in the Department of Electrical and Electronics Engineering, Vels Institute of Science, Technology and Advanced Studies (VISTAS), Tamil Nadu, India. His field of interest includes electrical machines and control,

electric vehicle control and charging, power converters and power cable modeling. He can be contacted at email:shanmugam71.se@velsuniv.ac.in



Suriyan Kannadhasan is working as an Assistant Professor in the department of Electronics and Communication Engineering in Study World College of Engineering, Coimbatore, Tamilnadu, India. He is Completed the Ph.D in the field of Smart Antenna for Anna University in 2022. He is Twelve years of teaching and research experience. He obtained his B.E in ECE from Sethu Institute of Technology, Kariapatti in 2009 and M.E in Communication Systems from Velammal College of Engineering and Technology, Madurai in 2013. He obtained his M.B.A in Human Resources Management from Tamilnadu Open University, Chennai. He has published around 45 papers in the reputed indexed international journals indexed by SCI, Scopus, Web of science, Major indexing and more than 146 papers presented/published in national, international journal and conferences. Besides he has contributed a book chapter also. He also serves as a board member, reviewer, speaker, session chair, advisory and technical committee of various colleges and conferences. He is also to attend the various workshop, seminar, conferences, faculty development programme, STTP and Online courses. His areas of interest are Smart Antennas, Digital Signal Processing, Wireless Communication, Wireless Networks, Embedded System, Network Security, Optical Communication, Microwave Antennas, Electromagnetic Compatability and Interference, Wireless Sensor Networks, Digital Image Processing, Satellite Communication, Cognitive Radio Design and Soft Computing techniques. He is Member of IEEE, ISTE, IEI, IETE, CSI, IAENG, SEEE, IEAE, INSC, IARDO, ISRPM, IACSIT, ICSES, SPG, SDIWC, IJSPR and EAI Community.



R Nagarajan received his B.E. in Electrical and Electronics Engineering from Madurai Kamarajar University, Madurai, India, in 1997. He received his M. E. in Power Electronics and Drives from Anna University, Chennai, India, in 2008. He received his Ph. D in Electrical Engineering from Anna University, Chennai, India, in 2014. He has worked in the industry as an Electrical Engineer. He is currently working as Professor of Electrical and Electronics Engineering at Gnanamani College of Technology, Namakkal, Tamilnadu, India. His current research interest includes Power Electronics, Power System, Soft Computing Techniques and Renewable Energy Sources.



Kanagaraj Venusamy is an Assistant Professor at Rajalakshmi Engineering College in Chennai, Tamilnadu, India. He obtained his undergraduate degree in Electronics and Communication Engineering (2005). He has received his Master of Business Administration in Production Management from Manonmaniam Sundaranar University in 2011. He received a Master of Engineering in Mechatronics from Anna University affiliated College-Rajas college in 2019. His main area of awareness is Robotics, Drone, Industrial automation, Artificial Intelligence, Internet of Things, Embedded System, Entrepreneurship and Human Resource Development. He had a ten years of teaching experience in reputed academic Institution in India and Sultanate of Oman. He has technically assisted in various academic Projects, Robotics International Competition, TRC-Oman funded Projects. He acted as Course facilitator in numerous short term course and Workshop which is organized by IEEE-UTAS-AI mussanah. His team won GCC level and national level Robotics competition in the year of 2017, 2018 and 2019. He has published journals, book chapter and Conferences in high indexed platform. He has conducted various technical workshop in online mode in the following area Robotics, Embedded system, Drone and Machine Learning during pandemic period (2020-2021).

ORCID

Nagarajan R  <http://orcid.org/0000-0002-4990-5869>

Kanagaraj Venusamy  <http://orcid.org/0000-0001-9479-8073>

References

- Arefifar, S. A., Mohamed, Y. A. I., & El-Fouly, T. H. M. (2012). Supply- Adequacy-based optimal construction of micro-grids in smart distribution systems. *IEEE Transactions on Smart Grid*, 3(3), 1491–1502. <https://doi.org/10.1109/TSG.2012.2198246>
- Arefifar, S. A., Mohamed, Y. A. R. I., & El-Fouly, T. H. M. (2013). Comprehensive operational planning framework for self-healing control actions in smart distribution grids. *IEEE Transactions on Power Systems*, 28(4), 4192–4200. <https://doi.org/10.1109/TPWRS.2013.2259852>
- Atwa, Y. M., & El-Saadany, E. F. (2010). Optimal allocation of ESS in distribution systems with a high penetration of wind energy. *IEEE Transactions on Power Systems*, 25(4), 1815–1822. <https://doi.org/10.1109/TPWRS.2010.2045663>
- Atwa, Y. M., & El-Saadany, E. F. (2011). Probabilistic approach for optimal allocation of wind-based distributed generation in distributionsystems. *IET Renewable Power Generation*, 5(1), 79–88. <https://doi.org/10.1049/iet-rpg.2009.0011>
- Atwa, Y. M., El-Saadany, E. F., Salama, M. M. A., Seethapathy, R., Assam, M., & Conti, S. (2011). Adequacy evaluation of distribution system including wind/solar DG during different modes of operation. *IEEE Transactions on Power Systems*, 26(4), 1945–1952. <https://doi.org/10.1109/TPWRS.2011.2112783>
- Bahramirad, S., Reder, W., & Khodaei, A. (2012). Reliability-constrained optimal sizing of energy storage system in a microgrid. *IEEE Transactions on Smart Grid*, 3(4), 2056–2062. <https://doi.org/10.1109/TSG.2012.2217991>
- Banupriya, R., & Nagarajan, R. (2021). A single feed-forward extreme learning machines based multilevel inverter for reduced harmonic distortion. *Journal of Green Engineering (JGE)*, 11(3), 2041–2054. <http://www.jgenng.com/volume11-issue3.php>
- Bhuiyan, F. A., & Yazdani, A. (2010). Reliability assessment of a wind-power system with integrated energy storage. *IET Renewable Power Generation*, 4(3), 211–220. <https://doi.org/10.1049/iet-rpg.2009.0070>
- Chaojie, L. (2021). AI-powered energy internet towards carbon neutrality: Challenges and opportunities. *TechRxiv*, 8(2). <https://doi.org/10.36227/techrxiv.14787573.v1>
- Chen, C., Duan, S., Cai, T., Liu, B., & Hu, G. (2011). Optimal allocation and economic analysis of energy storage system in microgrids. *IEEE Transactions on Power Electronics*, 26(10), 2762–2773. <https://doi.org/10.1109/TPEL.2011.2116808>
- Chowdhury, A. A., & Koval, D. O. (2004). Current practices and customer value-based distribution system reliability planning. *IEEE Transactions on Industry Applications*, 40(5), 1174–1182. <https://doi.org/10.1109/TIA.2004.834075>
- Cie'slik, S. (2014). Voltage control in low-voltage distribution grids with micro-sources (in Polish: Regulacja napięciawsieciachdystrybucyjnych z mikroinstalacjami). *Proceedings of the Symposium, WspółczesneUrządzeniaOrazUsługiElektroenergetyczne, Telekomunikacyjnej i Informatycznej*, Poznan', Poland, EAI CORE, 19–20 November; pp. 24–27.
- Fortenbacher, P., Zellner, M., & Andersson, G., “Optimal sizing and placement of distributed storage in low voltage networks”, *Power Systems Computation Conference (PSCC)*, 2016: IEEE, (2016), pp. 1–7.
- Gaun, A., Rechberger, G., & Renner, H. (2010). Probabilistic reliability optimization using hybrid genetic algorithms. *Electric Power Quality and Supply Reliability Conf. (PQ)*, 151–158. <https://www.infona.pl/resource/bwmeta1.element.ieee-art-000005550003>
- Goel, L., & Billinton, R. (1994). Determination of reliability worth for distribution system planning. *IEEE Transactions on Power Delivery*, 9(3), 1577–1583. <https://doi.org/10.1109/61.311207>
- Goswami, S. K., & Basu, S. K. (1992). A new algorithm for the reconfiguration of distribution feeders for loss minimization. *IEEE Transactions on Power Delivery*, 7(3), 1484–1491. <https://doi.org/10.1109/61.141868>
- Hannan, M. A., Wali, S. B., Ker, P. J., Abd Rahman, M. S., Mansor, M., Ramachandaramurthy, V. K., Muttaqi, K. M., Mahlia, T. M. I., & Dong, Z. Y. (2021). Battery energy-storage system: A review of technologies, optimization objectives, constraints, approaches, and outstanding issues. *Journal of Energy Storage*, 42(103023), 103023. <https://doi.org/10.1016/j.est.2021.103023>
- Hegazy, Y. G., Salama, M. M. A., & Chikhani, A. Y. (2003). “Adequacy assessment of distributed generation systems using Monte carlo simulation”. *IEEE Transactions on*

- Power Systems*, 18(1), 48–52. <https://doi.org/10.1109/TPWRS.2002.807044>
- Hetzer, J., Yu, D. C., & Bhattarai, K. (2008). An economic dispatch model incorporating wind power. *IEEE Transactions on Energy Conversion*, 23(2), 603–611. <https://doi.org/10.1109/TEC.2007.914171>
- Hu, P., Billinton, R., & Billinton, R. (2009). Reliability evaluation of generating systems containing wind power and energy storage. *IET Generation, Transmission & Distribution*, 3(8), 783–791. <https://doi.org/10.1049/iet-gtd.2008.0639>
- Jafari, M., & Botterud, A. (2022). Apurba sakti, decarbonizing power systems: A critical review of the role of energy storage. *Renewable and Sustainable Energy Reviews*, 158, 112077. <https://doi.org/10.1016/j.rser.2022.112077>
- Kannan, S., Slochanal, S. M. R., & Padhy, N. P. (2005). Application and comparison of metaheuristic techniques to generation expansion planning problem. *IEEE Transactions on Power Systems*, 20(1), 466–475. <https://doi.org/10.1109/TPWRS.2004.840451>
- Makarov, Y. V., Du, P., Kintner-Meyer, M. C., Jin, C., & Illian, H. F. (2012). Sizing energy storage to accommodate high penetration of variable energy resources. *IEEE Transactions on Sustainable Energy*, 3(1), 34–40. <https://doi.org/10.1109/TSTE.2011.2164101>
- Manwell, J., Rogers, A., Hayman, G., Avelar, C. T., McGowan, J. G., Abdulwahid, U., & Wu, K. (2006). *'Hybrid2: A hybrid system simulation model theory manual'* (Renewable energy research laboratory, Department of Mechanical Engineering. University of Massachusetts.
- Miranda, I., Silva, N., & Leite, H. (2016). A holistic approach to the integration of battery energy storage systems in island electric grids with high wind penetration. *IEEE Transactions on Sustainable Energy*, 7(2), 775–785. <https://doi.org/10.1109/TSTE.2015.2497003>
- Nagarajan, R., & Saravanan, M. (2014). Performance analysis of a novel reduced switch cascaded multilevel inverter. *Journal of Power Electronics*, 14(1), 48–60. <http://dx.doi.org/10.6113/JPE.2014.14.1.48>
- Niknam, T., & Doagou-Mojarrad, H. (2012). Multiobjective economic/emission dispatch by multiobjective -particle swarm optimisation. *IET Generation Transmission & Distribution*, 6(5), 363–377. <https://doi.org/10.1049/iet-gtd.2011.0698>
- Ramya, G., & Nagarajan, R. (2020). Multiple peak optimization in solar energy conversion system using hybrid bat optimization and LSTM networks. *Journal of Green Engineering (JGE)*, 10(11), 10851–10863. <http://www.jgenng.com/volume10-issue11.php>
- Sanduleac, M., Albu, M., Stanescu, D., & Stanescu, C. (2019). Grid storage in LV networks—An appropriate solution to avoid network limitations in high RES scenarios. *Proceedings of the 2019 International Conference on Electromechanical and Energy Systems (SIELMEN)*, Craiova, Romania, 9–11 October; pp. 1–6.
- Shaaban, M. F., Atwa, Y. M., & El-Saadany, E. (2013). DG allocation for benefit maximization in distribution networks. *IEEE Transactions on Power Systems*, 28(2), 639–649. <https://ieeexplore.ieee.org/stamp/stamp.jsp?arnumber=6687292>
- Sullivan, M. J., Mercurio, M. G., & Schellenberg, J. A. (2009). *Estimated value of service reliability for electric utility customers in the United States*. LBNL Research Project Final Report. LBNL Research Project
- Tang, J., Cai, D., Yuan, C., Qiu, Y., Deng, X., & Huang, Y. (2019). Optimal configuration of battery energy storage systems using for rooftop residential photovoltaic to improve voltage profile of distributed network. *The Journal of Engineering*, 2019(16), 728–732. <https://doi.org/10.1049/joe.2018.8386>
- Vai, V., Alvarez-Herault, M.-C., Raison, B., & Bun, L. (2020). Optimal low-voltage distribution topology with Integration of PV and storage for rural electrification in developing countries: A case study of Cambodia. *Journal of Modern Power Systems and Clean Energy*, 8(3), 531–539. <https://doi.org/10.35833/MPCE.2019.000141>
- Wacker, G., & Billinton, R. (1989). Customer cost of electric service interruptions. *Proceedings of the IEEE*, 77(6), 919–930. <https://doi.org/10.1109/5.29332>
- Wang, P., Ding, Y., & Goel, L. (2009). Reliability assessment of restructured power systems using optimal load shedding technique. *IET Generation, Transmission & Distribution*, 3(7), 628–640. <https://doi.org/10.1049/iet-gtd.2008.0308>
- Wei, H., King, M., Luo, X., Dooner, M., Dacheng, L., & Wang, J. (2021). Technologies and economics of electric energy storages in power systems: Review and perspective. *Advances in Applied Energy*, 4(4), 100060. <https://doi.org/10.1016/j.adapen.2021.100060>
- Xiao, J., Bai, L., Li, F., Liang, H., & Wang, C. (2014). Sizing of energy storage and diesel generators in an isolated microgrid using discrete Fourier transform (DFT). *IEEE Transactions on Sustainable Energy*, 5(3), 907–916. <https://doi.org/10.1109/TSTE.2014.2312328>
- Xiao, J., Bai, L., Lu, Z., & Wang, K. (2014). Method, implementation and application of energy storage system designing. *International Transactions on Electrical Energy Systems*, 24(3), 378–394. <https://doi.org/10.1002/etep.1703>
- Xiao, J., Bai, L., Wang, C., & Yu, J. (2012). Method and software for planning and designing of microgrid. *ZhongguoDianjiGongchengXuebao (Proc. of the Chinese Society of Electrical Engineering)*, 32(25), 149–157. <https://doi.org/10.1109/TSTE.2014.2312328>
- Yan, S., Nai-Shan, H., & Zhi-Yuan, S., “Power flow calculation method for islanded power network,” in *Proceeding of Asia-Pacific Power Energy Engineering Conference*. (APPEEC), Wuhan, China, 28–31, 2009, pp. 1–5.
- Yi, Z., Songzhe, Z., & Chowdhury, A. A. (2011). Reliability modeling and control schemes of composite energy storage and wind generation system with adequate transmission upgrades. *IEEE Transactions on Sustainable Energy*, 2(4), 520–526. <https://doi.org/10.1109/TSTE.2011.2160663>
- Zhang, Y., Dong, Z. Y., Luo, F., Zheng, Y., Meng, K., & Wong, K. P. (2016). Optimal allocation of battery energy storage systems in distribution networks with high wind power penetration. *IET Renewable Power Generation*, 10(8), 1105–1113. <https://doi.org/10.1049/iet-rpg.2015.0542>
- Zhang, J., Li, C., Chen, G., & Dong, Z. (2022). Planning of hydrogen refueling stations in urban setting while considering hydrogen redistribution. *IEEE Transactions on Industry Applications*, 58(2), 2898–2908. <https://doi.org/10.1109/TIA.2021.3122785>
- Zhao, H., Wu, Q., Huang, S., Guo, Q., Sun, H., & Xue, Y., “Optimal siting and sizing of energy storage system for power systems with large-scale wind power integration”, *PowerTech, 2015 IEEE Eindhoven*: IEEE, (2015), pp. 1–6.